



Dimensions

Width:	24.00"
Height:	28.00"
Depth:	31.00"

Options

- **Pressure Gauge Kit:**
Indicates when filters require cleaning.
- **HEPA High Efficiency After-Filter:**
Provides 99.97% filtration efficiency.
- **Adsorption Module:**
Charcoal after-filter removes gases and odors.
- **Hopper with Floor Stand:**
10 gallon container.
- **Regulator**

DCH-1 Dust Collector

Features & Benefits

- **Complete, self-contained unit:**
Economical; immediately functional.
- **Direct-Drive or FRP Blower:**
Higher static pressure, longer filter life and greater reliability; non-sparking; no belts or pulleys to replace.
- **Non-electrostatic operation:**
High reliability, low maintenance.
- **Ultra-Seal® filter mounting:**
Eliminates contaminant bypass of filters.
- **Vibra-Pulse® Filter Cleaning System:**
Cleans filters 75% more effectively than reverse pulse systems.
- **Low profile cabinet:**
Easy access speeds filter changeout and maintenance.

Specifications

Construction:

12/14/16 ga. welded steel, powder coated cabinet

Blower Pkgs (HP):

1.0, 1.5

Noise Level (dBA):

71/77

Electrical:

1.0 HP - 115/1/60, 12 amps, std.;

1.5 HP - 115/208-230/1/60, 15/7.9-7.5 amps, opt.

1.0 HP - 220/1/50, 6.6 amps

1.0 HP - 190/38/3/50, 4.8/2.4 amps.

Nominal CFM (in.):

650/800

Weight (lbs.):

200

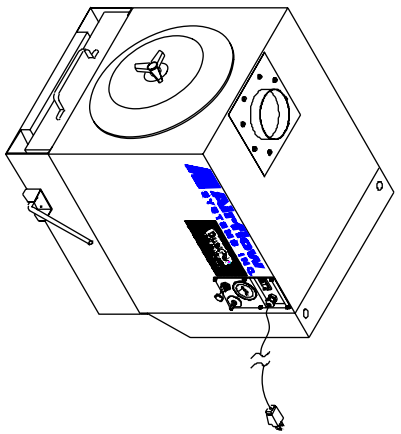
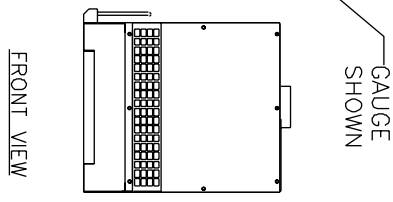
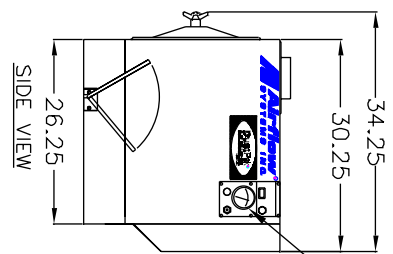
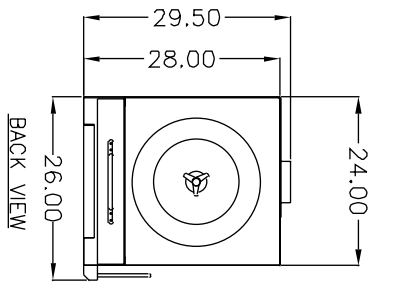
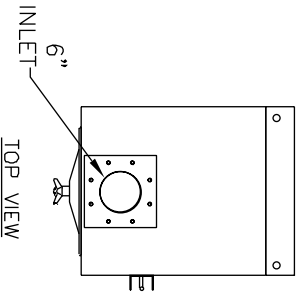

SPECIFICATIONS:

CONSTRUCTION:

12/14/16 Gauge steel cabinet finished with Powder-Coat Finish. Includes a 5 gallon external dust drawer, removable end cap for easy access to filter, removable panel for easy access to direct drive motor/blower, 25" 12 Ga. power cord, and on-off switch. Motor wired to junction box outside unit for 3 phase option. Acoustical lining standard in blower compartment. Vibro-Pulse cleaning standard.

WEIGHT:

200 lbs.

AIRFLOW:

600 CFM with std. 1 HP motor
800 CFM with opt. 1.5 HP motor

NOISE:

71 dBA

ELECTRICAL:

- 1 HP 115 /1/60, 12 amps, std.
- 1.5 HP 115/220/1/60, 15/7.9-7.5 amps, opt.
- 1.5 HP 230/460/3/60, 4.9-4.6/2.3 amps, opt.

FIRE SUPPRESSION:

Equipment provided by others.

SPECIAL NOTES:

Compressed air filter provided by others.

MAIN FILTERS:

- (1) CLEAN-2[®] Filter cartridge, 16"Dx12", Std.
- (1) Cartridge, FIBERDUST[®] Opt.
- (1) Cartridge, Spark Resistant, Opt.
- (1) Cartridge, Spunbond - H₂O, Opt.
- (1) Cartridge, CleanPlus double treated fire retardant, Opt.

HEPA OPTIONS:

- (1) External HEPA filter, 99.97%

AD. OPTION:

- (1) External adsorber, 25 lb. capacity

OTHER OPTIONS:

- Pressure gauge kit indicates filter changes
- Hopper option, 10 Gallon
- Auto Clean (Hopper opt. recommended)
- Regulator
- Silencer (Adds 3" to depth of unit)

* AFS FILTER EFFICIENCIES BASED ON ASHRAE 52-76 TEST METHOD

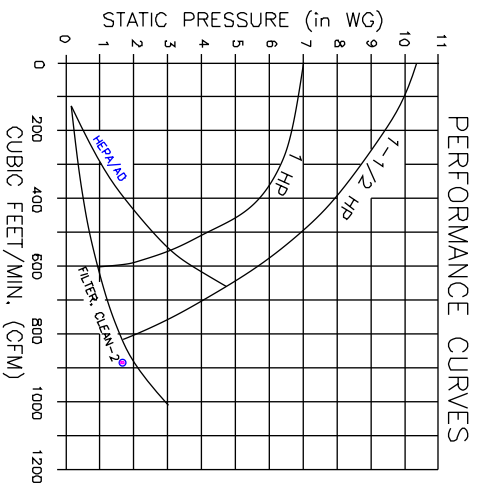

NOTES:
Items designated as are included in this proposal.

THE DEVICE DEPICTED AND DESCRIBED HEREON EMBODIES PROPRIETARY INFORMATION OWNED BY AIRFLOW SYSTEMS, INC. ALL DESIGN, MANUFACTURING, REPRODUCTION, SALES, AND PATENT RIGHTS REGARDING THIS DEVICE OR DRAWING ARE RESERVED EXCEPT WHERE EXPLICIT RIGHT IS GRANTED IN WRITING.

Diversified Air Systems, Inc.
Phone: 800-264-8958

DRAWN BY CB	TITLE MODEL DCH1 (CARTRIDGE)
DATE 4-20-00	PAGE 1 OF 2
SCALE	DRAWING NO.: DCH1SPEC (58-2622/B)

HOPPER OPTION AND
EXTERNAL HEPA/AD
OPTION

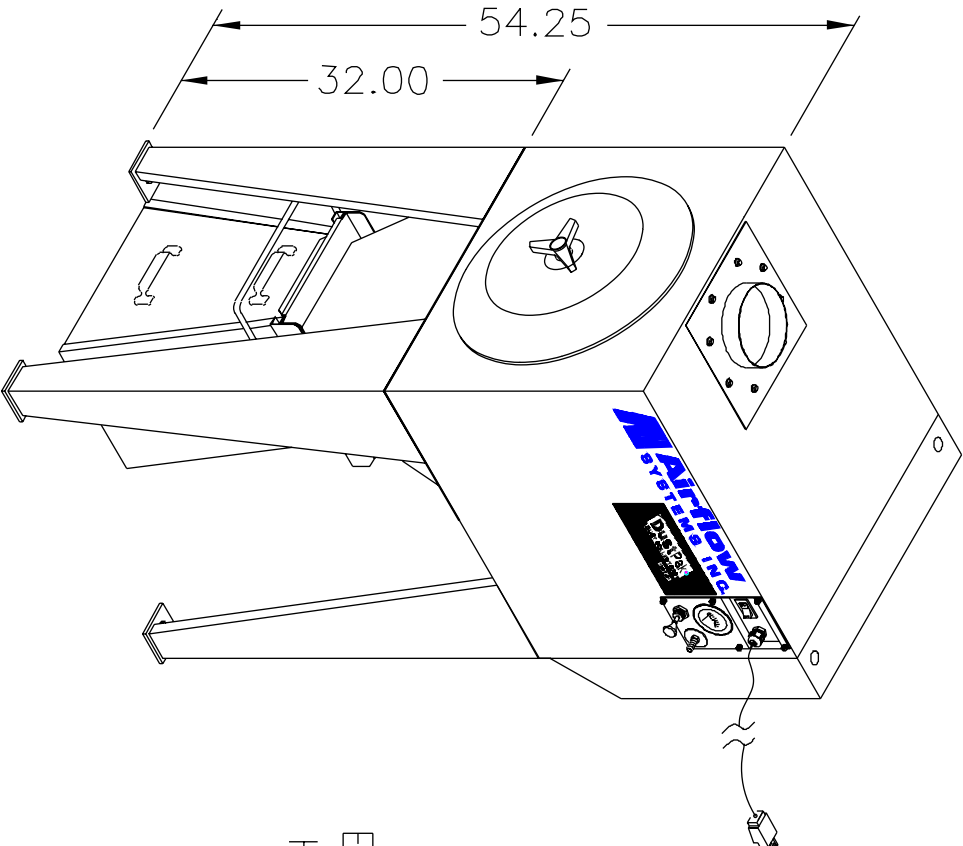

EXTERNAL
HEPA/AD
OPTION

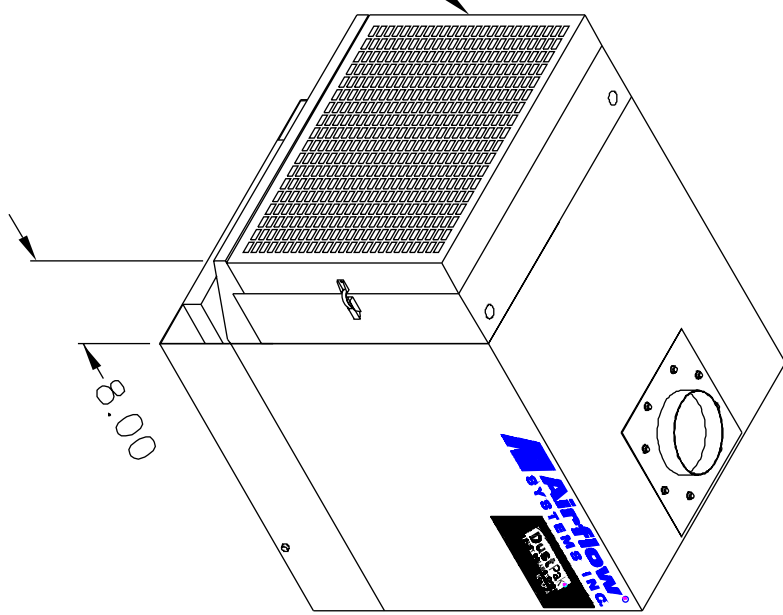

NOTES:

THE DEVICE DEPICTED AND DESCRIBED
HEREON EMBODIES PROPRIETARY
INFORMATION OWNED BY AIRFLOW SYSTEMS,
INC. ALL DESIGN, MANUFACTURING,
REPRODUCTION, SALES, AND PATENT RIGHTS
REGARDING THIS DEVICE OR DRAWING ARE
RESERVED EXCEPT WHERE EXPLICIT RIGHT
IS GRANTED IN WRITING.

Diversified Air Systems, Inc.
Phone: 800-264-8958

DRAWN BY CB	TITLE MODEL DCH1
DATE 4-20-00	PAGE 2 OF 2
SCALE	DRAWING NO: DCH1SPEC (58-2622/B)