

DT-23 Nonpowered Downdraft Table



Dimensions

Width:	37.00"
Height:	29.00"
Depth:	25.00"

Options

- **Exhaust Blower**
- **Dust Collectors**
- **Center Divider and Side Shields:**
Improves collection efficiency; reduces contaminant migration.
- **Enclosures and Lighting:**
Enhances work area; encourages productivity.

Features & Benefits

- **Integral collection area and work surface:**
Draws contaminants away from workers' breathing zone without hindering movement.
- **10-inch duct connection:**
For connection to remote collection operation.
- **14 ga. welded steel construction, finished with chemical and oil resistant paint:**
Durable, able to withstand industrial use.
- **Built-in forklift slots:**
For convenient movement.

Specifications

Construction:
14 ga. welded steel, powder coated cabinet

Weight (lbs.):
180

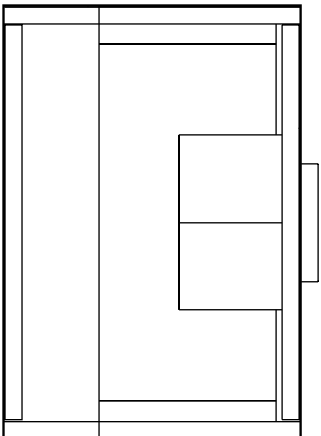

TOP VIEW

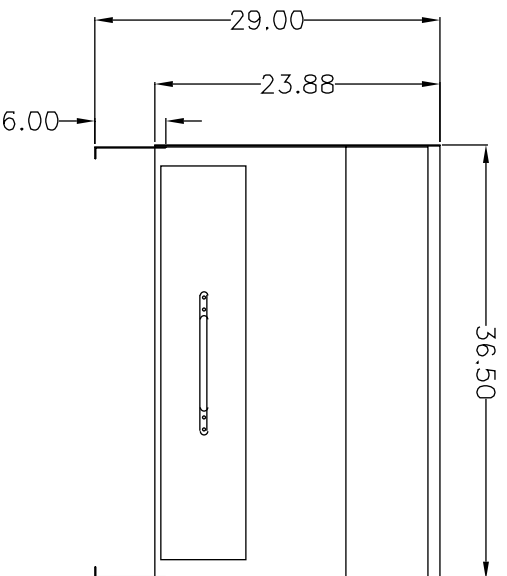

FRONT VIEW

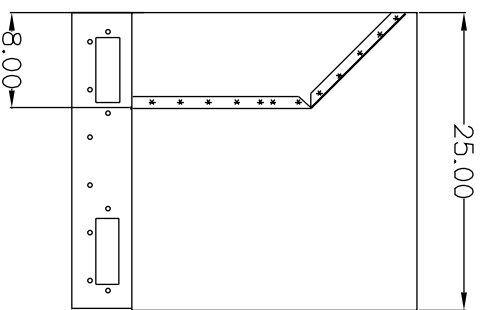

SIDE VIEW

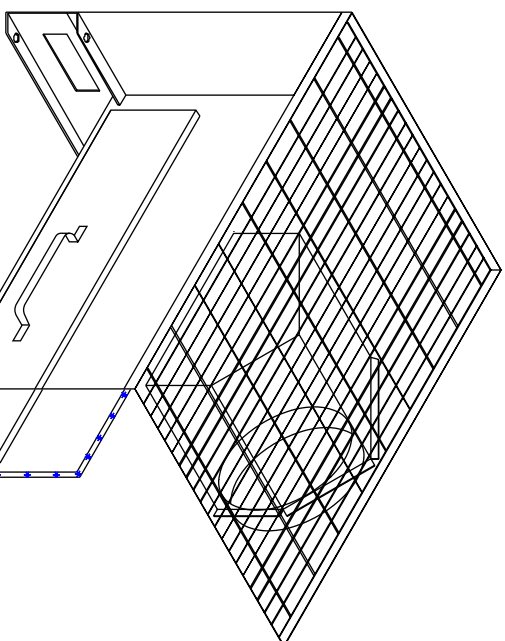

10" DIA.
DUCT
CONNECTION

20.00

CONSTRUCTION:

14 gauge steel cabinet finished with 2 part chemical and oil resistant paint, 36.50" x 25" work surface with a heavy duty 300 PSF rated steel grate (max. table loading 600 lbs.), 29.00" high, 10" duct connection on back for remote operation, 6" deep removable dust tray. Table only--no blower, no filters.

SPECIFICATIONS:

WEIGHT:

180 lbs.

FIRE SUPPRESSION:

Equipment provided by others.

NOTES:

THE DEVICE DEPICTED AND DESCRIBED HEREON EMBODIES PROPRIETARY INFORMATION OWNED BY AIRFLOW SYSTEMS, INC. ALL DESIGN, MANUFACTURING, REPRODUCTION, SALES, AND PATENT RIGHTS REGARDING THIS DEVICE OR DRAWING ARE RESERVED EXCEPT WHERE EXPLICIT RIGHT IS GRANTED IN WRITING.

Diversified Air Systems, Inc.
Phone: 800-264-8958

DRAWN BY JKS	TITLE MODEL DT-23
DATE 4-5-99	BLOWERLESS DD TABLE
SCALE	DRAWING NO.: DT23SPEC (00-2087/F)