

# DTH-800 Downdraft Table



## Dimensions

Width:	32.00"
Height:	33.00"
Depth:	24.00"

## Options

- **Pressure Gauge Kit:**  
Indicates when filters require cleaning.
- **Silencer:**  
Reduces noise by 3 dBA.
- **Cartridge Media:**  
For specific applications.
- **After-Filters:**  
99.97% HEPA, 95%, and odor-control modules.
- **Center Divider and Side Shields:**  
Improves collection efficiency; eliminates contaminant migration.
- **Enclosures and Lighting:**  
Enhances work area; encourages productivity.
- **Regulator**

## Features & Benefits

- **Integral collection area and work surface:**  
Draws contaminants away from workers' breathing zone without hindering movement; portable for location anywhere in facility.
- **Direct-Drive or FRP Blower:**  
Higher static pressure, longer filter life and greater reliability; non-sparking; no belts or pulleys to replace.
- **Non-electrostatic operation:**  
High reliability, low maintenance.
- **Ultra-Seal® filter mounting:**  
Eliminates contaminant bypass of filters.
- **Low profile cabinet:**  
Easy access speeds filter changeout and maintenance.
- **Vibra-Pulse® Filter Cleaning System:**  
Cleans filters 75% more effectively than reverse pulse systems.
- **Dust Drawer:**  
Easily remove external dust drawer with positive level lock

## Specifications

### Construction:

16 ga. welded steel, powder coated cabinet

### Blower Pkgs (HP):

1.0, 1.5

### Noise Level (dBA):

75/78

### Electrical:

1 HP - 115/1/60, 12 amps, std.;  
1.5 HP - 115/208-230/1/60, 15/7.9 amps, opt.  
1.5 HP - 208/230/460/3/60, 4.9/4.6/23 amps  
1 HP - 220/1/50, 6.6 amps.

### Downdraft Velocity (FPM):

122/150

### Weight (lbs.):

260

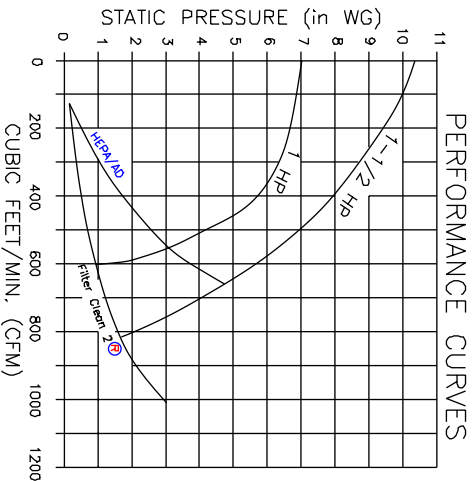
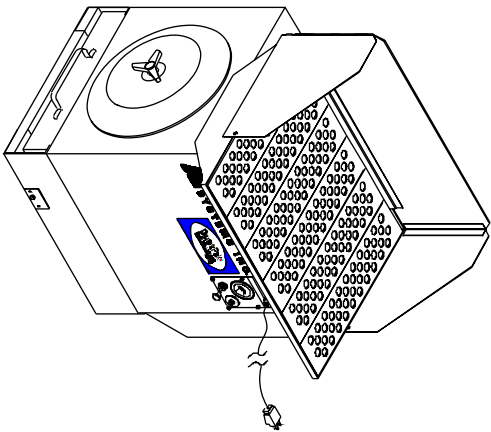
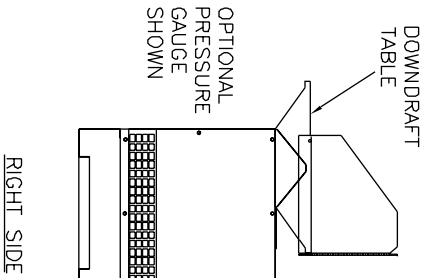
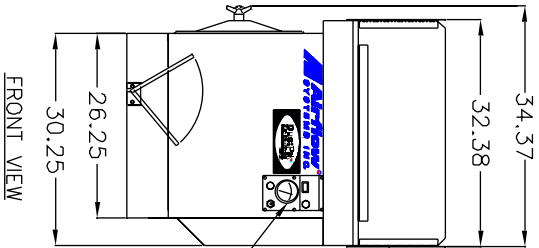
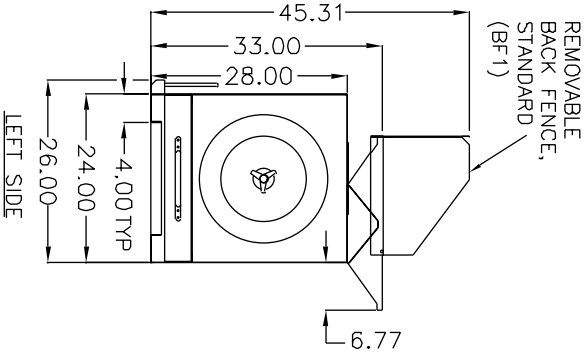
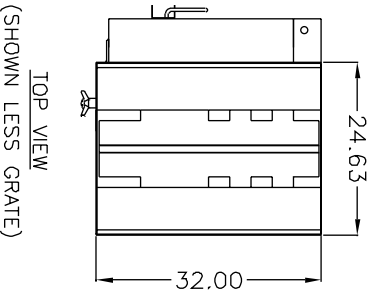

**CONSTRUCTION:**

12/14/16 Gauge steel cabinet finished with Powder-Cool Finish. Includes a 5 gallon external dust drawer, 5" deep downdraft table with removable back fence, removable end cap for easy access to filter, removable panel for easy access to direct drive motor/blower, 25' 12 Ga. power cord, and on-off switch. Motor wired to junction box outside unit for 3 phase. Acoustical lining standard in blower compartment. Vibra-Pulse cleaning standard.

**WEIGHT:**

260 lbs.

**DOWNDRAFT VELOCITY:**

112 FPM with std. 1 HP motor  
150 FPM with opt. 1.5 HP motor

**NOISE:**

75 dBA

**ELECTRICAL:**

- 1 HP 115/1/60, 12 amps, std.
- 1.5 HP 115/208-230/1/60, 15/7.9-7.5 amps, opt.
- 1.5 HP 208-230/460/3/60, 4.9-4.6/2.3 amps, opt.

**FIRE SUPPRESSION:**

Equipment provided by others.

**SPECIAL NOTES:**

Compressed air filter provided by others.

**SPECIFICATIONS:**

**MAIN FILTERS:**

- (1) Clean-2<sup>®</sup> cart., 16" dia. w/150 ft<sup>2</sup> media, std.
- (1) Cart. FIBERDUST<sup>®</sup> 16 dia w/75 ft<sup>2</sup> media, opt.
- (1) Cartridge, Spunbond, opt.
- (1) Cartridge, Spark Resistant, opt.
- (1) Cart., Spunbond - HO, opt.
- (1) Cartridge, CleanPlus double treated fire retardant, opt.

**HEPA OPTIONS:**

- (1) External HEPA filter, 99.97%
- (1) External adsorber, 25 lb. capacity

**AD OPTION:**

- Pressure gauge kit indicates filter changes

**OTHER OPTIONS:**

- Auto Clean
- Regulator
- Casters, increases table height by 3" to OA 36"
- BF3 w/Light
- Aluminum Grate
- Vinyl Grate
- Fiberglass Grate
- Silencer (Adds 3" to depth of unit)

\* AFS FILTER EFFICIENCIES BASED ON ASHRAE 52-76 TEST METHOD

**NOTES:**  
Items designated as  are included in this proposal.

THE DEVICE DEPICTED AND DESCRIBED HEREON EMBODIES PROPRIETARY INFORMATION OWNED BY AIRFLOW SYSTEMS, INC. ALL DESIGN, MANUFACTURING, REPRODUCTION, SALES, AND PATENT RIGHTS REGARDING THIS DEVICE OR DRAWING ARE RESERVED EXCEPT WHERE EXPLICIT RIGHTS IS GRANTED IN WRITING.

Diversified Air Systems, Inc.  
Phone: 800-264-8958

DRAWN BY: CB  
DATE: 2-27-01  
SCALE:

TITLE: MODEL DTH800  
PAGE 1 OF 2  
DRAWING NO.: DTH800SP (61-3073/D)

# BF-3 OPTION AND EXTERNAL HEPA/AD OPTION

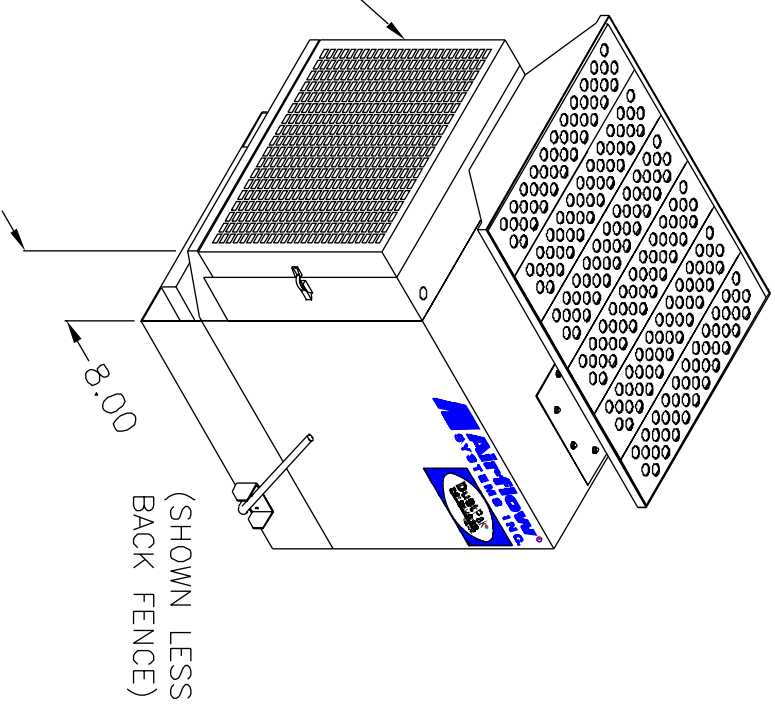
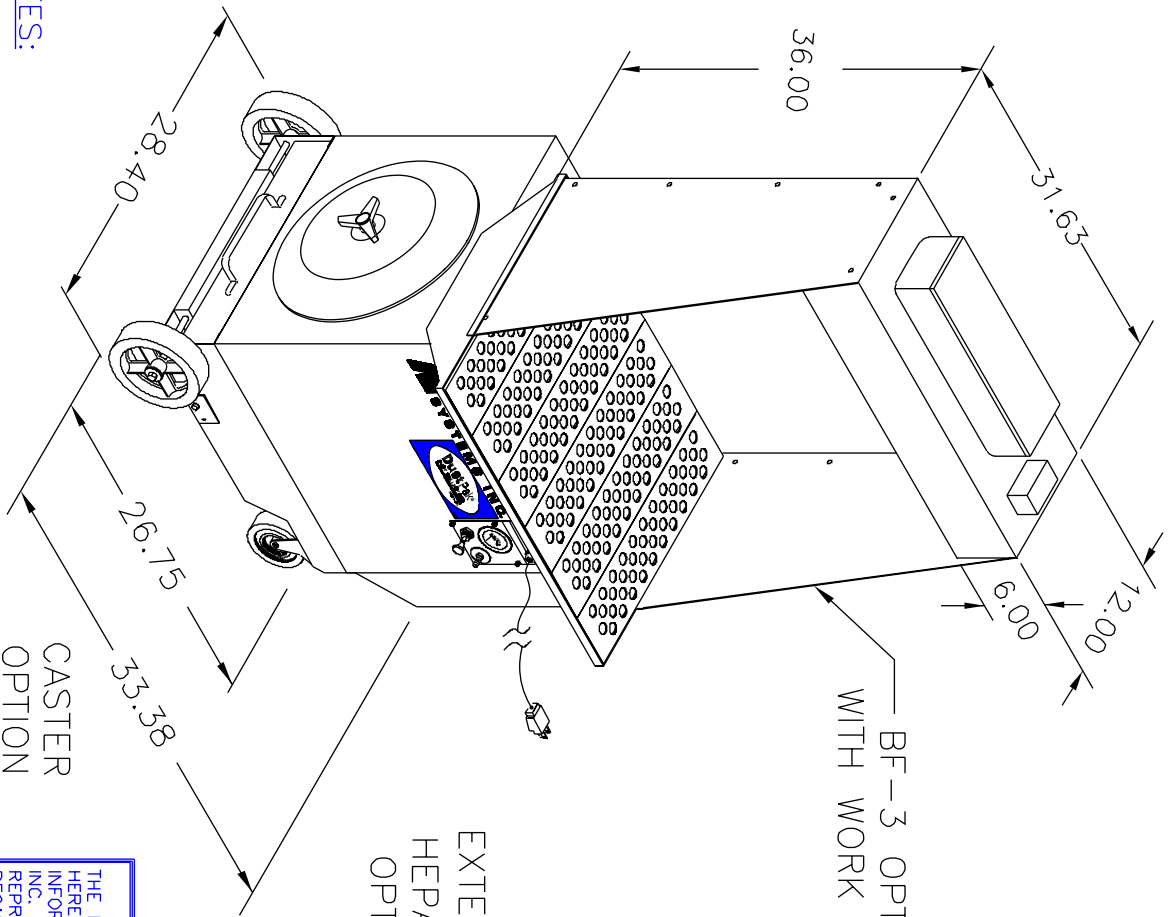

**NOTES:**

CASTER  
OPTION

THE DEVICE DEPICTED AND DESCRIBED  
HEREON EMBODIES PROPRIETARY  
INFORMATION OWNED BY AIRFLOW SYSTEMS,  
INC. ALL DESIGN, MANUFACTURING,  
REPRODUCTION, SALES, AND PATENT RIGHTS  
REGARDING THIS DEVICE OR DRAWING ARE  
RESERVED EXCEPT WHERE EXPLICIT RIGHT  
IS GRANTED IN WRITING.

**Diversified Air Systems, Inc.**  
Phone: 800-264-8958

DRAWN BY CB	TITLE MODEL DTH800
DATE 2-27-01	PAGE 2 OF 2
SCALE	DRAWING NO.: DTH800SP (61-3073/D)