

E-Z Arm® 2.5 Extractor Arm



Features & Benefits

- **2.5-in. dia. arm in 4- or 6-foot lengths**
Provides for high-efficiency source-point collection for close work areas.
- **4.75-in. dia. flanged intake hood:**
Increases collection area and efficiency.
- **Strong, extruded aluminum tubing:**
Epoxy powder coated for corrosion resistance; lightweight for one-hand positioning.
- **Triple-joint section design:**
Provides complete 360° range of movement, allows for positive positioning in any setup.
- **Heavy-duty stamped aluminum joints:**
External friction adjustments can handle continued repositioning with losing position integrity.
- **Universal wall/table mounting bracket:**
Allows multiple mounting options to maximize operator productivity and space usage.
- **Flange-up or flange-down design:**
Allows table or wall mounting configuration.

Options

- **Filtration Units:**
HEPA, cartridge, and odor-control filter systems available based on application.
- **Blower Packages:**
Multiple options available to meet application-specific criteria.

Specifications

Construction:

18 ga. extruded aluminum seamless tube with spiral flex duct

Arm Lengths:

4 ft. (E-Z Arm® 2.5 2EO4) , 6 ft. (E-Z Arm® 2.5 2EO6)

Blower Pkgs (HP):

consult factory

Nominal CFM (in.):

75 to 300

Weight (lbs.):

E-Z Arm® 2.5 2EO4 - 5 lbs., 2EO6 - 6 lbs.

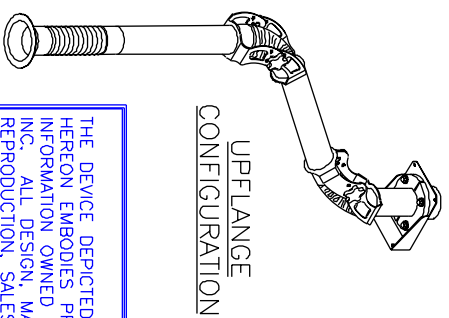
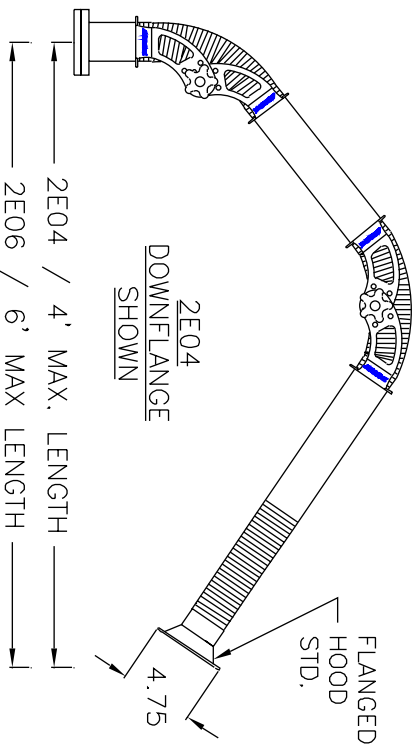
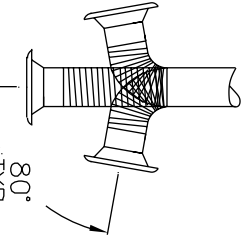
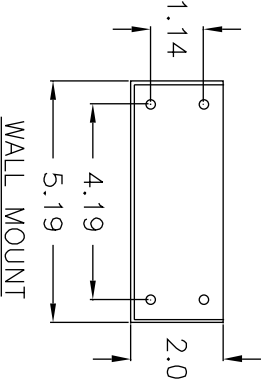
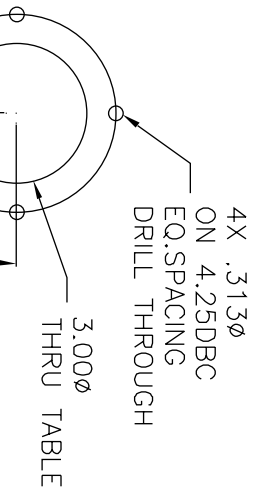

SPECIFICATIONS:

CONSTRUCTION: Aluminum tubes connected with a spiral flex duct. Heavy duty aluminum joints with easy external friction adjustment and double friction ring base joint. Comes standard with flanged hood, and universal wall/table mounting bracket. Finished with white epoxy powder coat.

WORKING TEMPERATURE: 104°F

- ARM LENGTH-WEIGHT:**
- 4 ft. - 5 lbs.
 - DOWNFLANGE
 - UPFLANGE
 - 6 ft. - 6 lbs.
 - DOWNFLANGE
 - UPFLANGE

FIRE SUPPRESSION: Equipment provided by others.

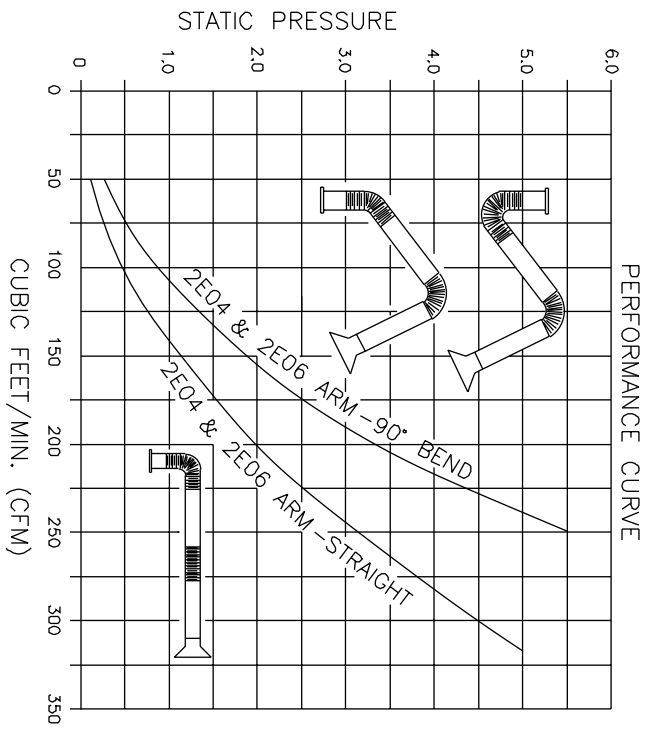

THE DEVICE DEPICTED AND DESCRIBED HEREON EMBODIES PROPRIETARY INFORMATION OWNED BY AIRFLOW SYSTEMS, INC. ALL DESIGN, MANUFACTURING, REPRODUCTION, SALES, AND PATENT RIGHTS REGARDING THIS DEVICE OR DRAWING ARE RESERVED EXCEPT WHERE EXPLICIT RIGHT IS GRANTED IN WRITING.

Diversified Air Systems, Inc.
 Phone: 800-264-8958

DRW BY: CB
 DATE: 11-10-99
 SCALE:

TITLE: E-Z ARM
 2.5" EXTRACTOR ARM
 DRAWING NO.: 2_SARMSP (02-2395/A)

NOTES:
 ITEMS DESIGNATED AS ARE INCLUDED IN THIS PROPOSAL