

TOP VIEW

CONSTRUCTION: 14/16 Ga. welded zinc coated steel cabinet, finished with a white Powder-Coat finish. Includes easy-seal magnetic covers for easy access to filters, catch pan, on/off switch, acoustically lined blower compartment, and a hinged grate/backsplash with 264, 3/4" diameter holes.

WEIGHT: 175 lbs.

AIRFLOW: 800 CFM
(STD AIR) 500 CFM W/HEPA or AD Module

NOISE: 66 dBA

ELECTRICAL: 115/1/60, 185 WATTS, std.
 220/1/50/60, 136 WATTS, opt.

FIRE SUPPRESSION: Equipment provided by others.

SPECIFICATIONS:

- FILTER COMBINATIONS:**
- (2) 4" MERV 11, std.
 - (2) 2" Poly and 2" MERV 11
 - (Each side must equal 4" of filter)
 - (2) 4" MERV 13, opt.
 - (2) 4" MERV 14, opt.
 - (2) 4" 95% DOP or 4" HEPA
 - (4) 2" Charcoal (includes 1" poly), opt.
 - (2) 3" Refillable charcoal w/ 1" poly, opt.
- ALUM. OPTION:** (2) 4" 65% pleated filters, aluminum top, casters, and switch located on power cord
- OTHER OPTIONS:**
- 1" High casters
 - 3/4" High feet
 - 3.50" High feet
 - Soft mat cover
 - Lift out catch tray
 - Clear acrylic backsplash extnsn to 16"

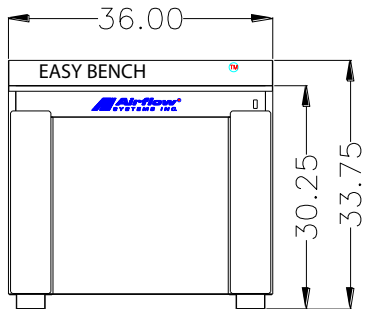

FRONT VIEW

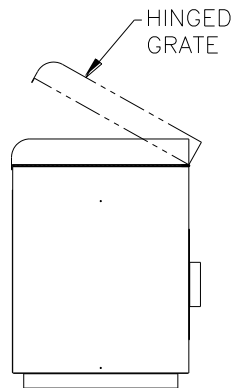

SIDE VIEW

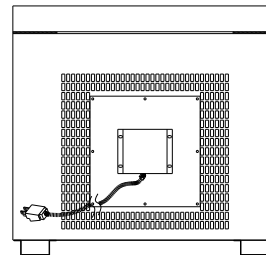

BACK VIEW

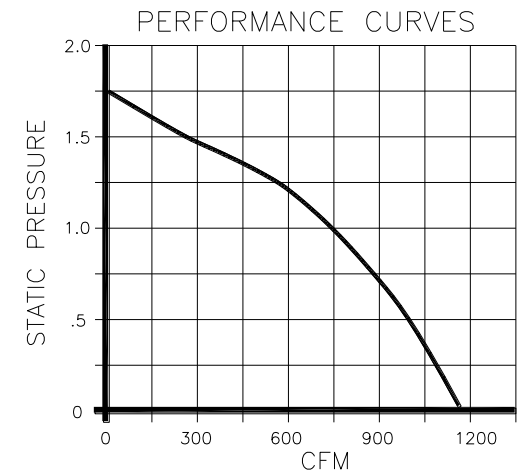
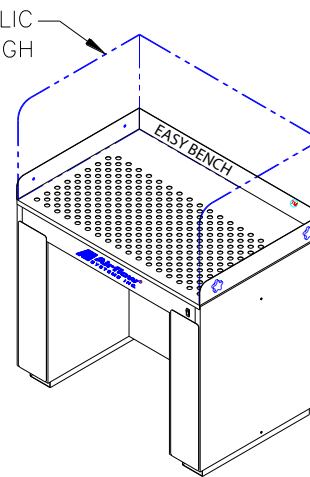

NOTES:

THE DEVICE DEPICTED AND DESCRIBED HEREON EMBODIES PROPRIETARY INFORMATION OWNED BY AIRFLOW SYSTEMS, INC. ALL DESIGN, MANUFACTURING, REPRODUCTION, SALES, AND PATENT RIGHTS REGARDING THIS DEVICE OR DRAWING ARE RESERVED EXCEPT WHERE EXPLICIT RIGHT IS GRANTED IN WRITING.

Diversified Air Systems, Inc.
Phone: 800-264-8958

DRAWN BY CB	TITLE PANEL FILTER DOWNDRAFT TABLE
DATE 9-27-06	DRAWING NO.: PFDTSPEC (49-4312/B)
SCALE	