



F70R Free-Hanging Dust Collector

Features & Benefits

- **Capacities to 2500 CFM:**
Handles toughest industrial applications.
- **Direct-drive blower:**
Long filter life and greater reliability; no belts or pulleys to replace.
- **Non-electrostatic operation:**
High reliability, low maintenance.
- **Ultra-Seal® filter mounting:**
Eliminates contaminant bypass of filters.
- **High efficiency filter media:**
provides maximum effectiveness; low air-to-cloth ratio extends cycles between filter changes; filter changes easily without tools.
- **Prewired:**
2 speed switch and power chord.

Dimensions

Width:	24.00"
Height:	24.00"
Length:	66.00"

Options

- **Pressure Gauge Kit:**
Indicates when filters require cleaning.
- **Silencer:**
Reduces air flow noise for quieter operation.
- **Charcoal Adsorber Modules:**
Refillable modules control gases and odors.
- **HEPA After-Filter:**
provides 99.97% DOP efficiency.
- **Backwards Inclined Blower:**
For operating at higher pressures.
- **Inlet Plenum**
- **Floor Stand:**
Allows on-floor mounting when on-machine or hanging mounts are impractical.

Specifications

- **Construction:**
18 ga. steel cabinet, powder coated
- **Blower Pkg (HP):**
.75
- **Noise Level (dBA):**
68/62 silencer
- **Electrical:**
.75 HP - 208-230/1/60, 11.4
.75 HP - 220/1/50, 3.8
- **Nominal CFM (in.):**
1400-2500, 60 Hz
1000-2000, 50 Hz
- **Weight (lbs.):**
170

SPECIFICATIONS:

CONSTRUCTION: 18 Gauge pointed steel cabinet with a hinged, quick release reduced maintenance prefilter plenum. Includes a direct drive 10"x10" blower w/4-way adjustable airfoil blade exhaust grille, a totally enclosed motor, and a 6' power cord and plug.

WEIGHT: 170 lbs.

AIRFLOW: 2500 CFM (HI) / 1400 CFM (LOW)

ELECTRICAL: 3/4 HP 115/1/60, 11.4 amps, 2 speed, std. 3/4 HP 208-230/1/60, 3.9 amps, opt. (with switch and cord, no plug).

NOISE: 68 dBA with silencer (right angle discharge)

PREFILTERS: (1) 2" polyester, 10H1² 98% bag (1) Auto roll, opt. (1) 4" pleat, opt.

MAIN FILTERS: (1) 98% bag, 66 ft², std. (1) 99% bag, opt. (1) Easy clean, opt.

OTHER OPTIONS: Pressure gauge kit indicates filter changes Silencer

* This unit can be flipped over for left to right airflow.

* AFS FILTER EFFICIENCIES BASED ON ASHRAE 52-76 TEST METHOD ALL FLOWS STANDARD AIR AND FILTERS UNLESS OTHERWISE INDICATED

OPTIONAL SILENCER AVAILABLE STRAIGHT OR RIGHT ANGLE DISCHARGE

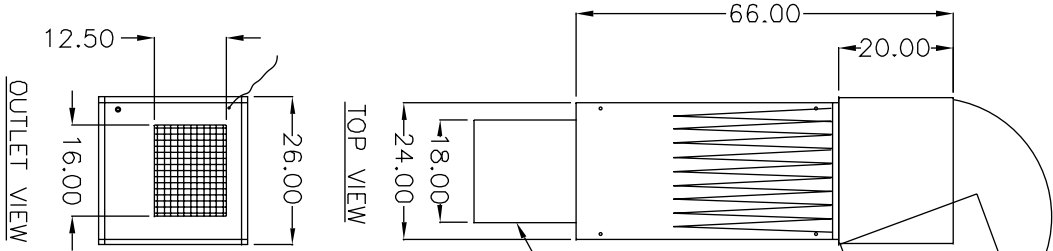

TOP VIEW

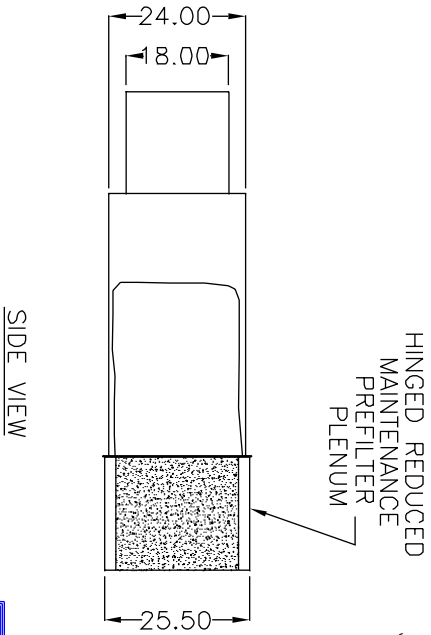

SIDE VIEW

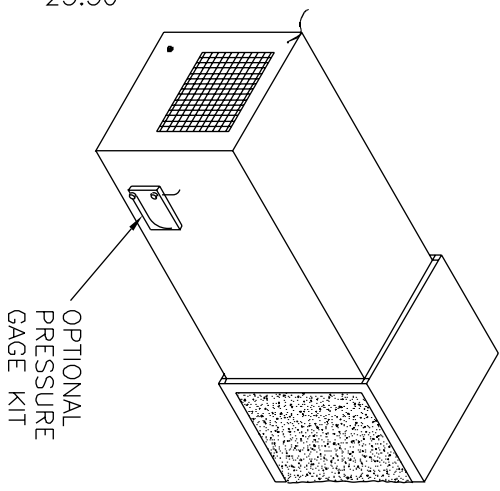

OPTIONAL PRESSURE GAUGE KIT

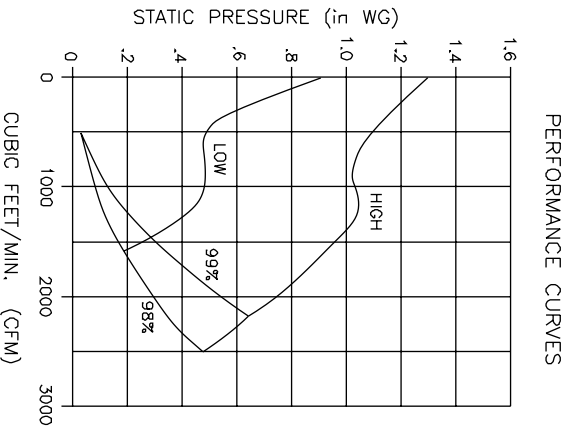

NOTES:

Items designated as are included in this proposal

THE DEVICE DEPICTED AND DESCRIBED HEREON EMBODIES PROPRIETARY INFORMATION OWNED BY AIRFLOW SYSTEMS, INC. ALL DESIGN, MANUFACTURING, REPRODUCTION, SALES, AND PATENT RIGHTS REGARDING THIS DEVICE OR DRAWING ARE RESERVED EXCEPT WHERE EXPLICIT RIGHT IS GRANTED IN WRITING.

Diversified Air Systems, Inc.
 Phone: 800-264-8958

DRAWN BY: CB
 DATE: 1-20-99
 SCALE:

TITLE: MODEL F70-R
 DRAWING NO.: F70RSPPEC (70-1982/G)

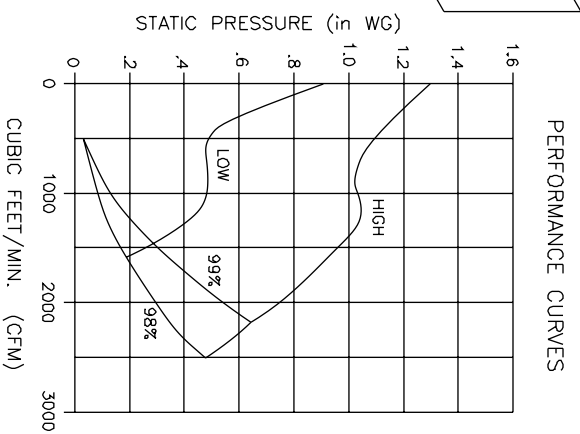
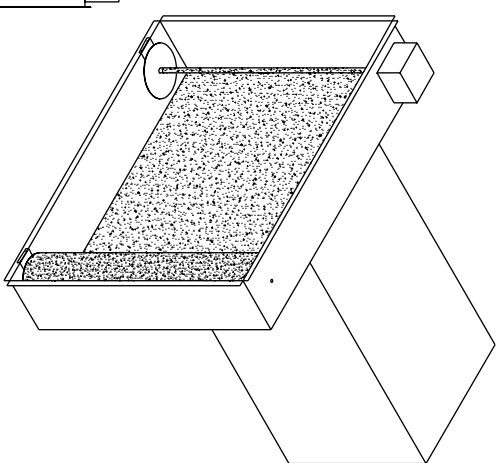
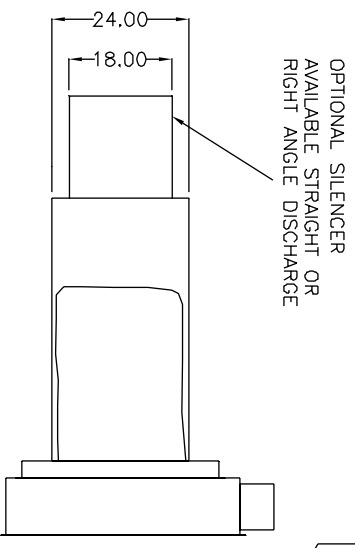
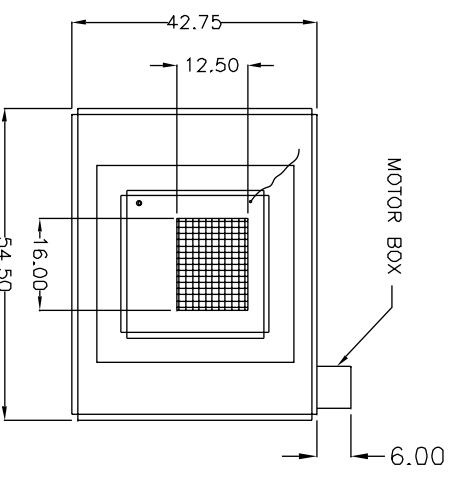
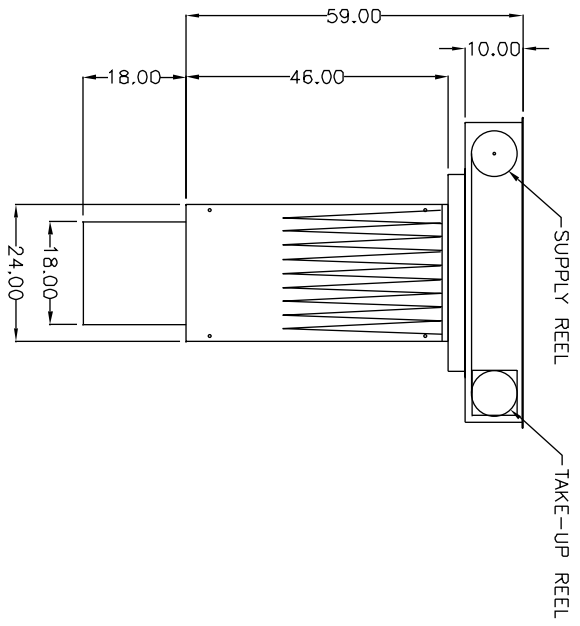

SPECIFICATIONS:

CONSTRUCTION: 18 Gauge painted steel cabinet with Auto-Roll prefilter that includes an automatic pressure switch advance mechanism plus media. Unit includes a direct drive 10" x 10" blower w/4-way adjustable airfoil blade exhaust grille, a totally enclosed motor, and a 6' power cord and plug.

WEIGHT: 370 lbs.

AIRFLOW: 2500 CFM (HI) / 1400 CFM (LOW)

ELECTRICAL: 3/4 HP 115/1/60, 11.4 amps, 2 speed, std. switch and cord, no plug). 3/4 HP 208-230/1/60, 3.9 amps, opt.

PREFILTERS:

- (1) Auto roll, 300 feet

MAIN FILTERS:

- (1) 98% bog, 66 ft² media, std.
- (1) 99% bog filter, opt.
- (1) Easy clean, opt.

OPTIONS:

- Pressure gauge kit indicates filter changes
- Silencer

* This unit can be flipped over for left to right airflow.
 * AFS FILTER EFFICIENCIES BASED ON ASHRAE 52-76 TEST METHOD
 ALL FLOWS STANDARD AIR AND FILTERS UNLESS OTHERWISE INDICATED

NOTES:

Items designated as are included in this proposal

OUTLET VIEW

SIDE VIEW

THE DEVICE DEPICTED AND DESCRIBED HEREON EMBODIES PROPRIETARY INFORMATION OWNED BY AIRFLOW SYSTEMS, INC. ALL DESIGN, MANUFACTURING, REPRODUCTION, SALES, AND PATENT RIGHTS REGARDING THIS DEVICE OR DRAWING ARE RESERVED EXCEPT WHERE EXPLICIT RIGHT IS GRANTED IN WRITING.

Diversified Air Systems, Inc.
 Phone: 800-264-8958

DRAWN BY CB	TITLE MODEL F70-R WITH AUTO-ROLL
DATE 5-19-98	DRAWING NO.: F70RWARL (70-1722)
SCALE	