



Shown With Optional  
Large Wheel Kit

# Mini-Pac Portable Air Cleaner/Collector

## Features & Benefits

---

- **Complete, self-contained unit:**  
Versatile, easy to use; no installation required.
- **10-ft. E-Z Arm® High Flow Extractor:**  
Self supporting external arm provides for maximum performance, reduces operator fatigue.
- **Efficient source capture:**  
95%+ filtration efficiency produces cleaner air; system simplifies OSHA and insurance compliance.
- **Direct-drive blower:**  
Higher static pressure, longer filter life and greater reliability; no belts or pulleys to replace.
- **Non-electrostatic operation:**  
High reliability, low maintenance.
- **Narrow width design:**  
Permits access and maneuverability in tight spaces.
- **Plug-in operation with any 115V outlet:**  
Can be used anywhere, no special wiring required.

## Dimensions

---

<b>Width:</b>	24.00"
<b>Height:</b>	42.00"
<b>Depth:</b>	25.00"

## Options

---

- **Dual 4 Arms:**  
Provides up to 300 CFM per arm.
- **HEPA Final Filters:**  
99.97% DOP efficiency.
- **Adsorption Filter:**  
Refillable filter to control gases and odors; available with a variety of sorbents.
- **65-Watt Halogen Light Kit:**  
Improves worker visibility.
- **Oversized Wheels:**  
Provides additional stability, ideal for rolling over rough surfaces.
- **Hazard Location Electrical:**  
Groups D, E, F, and G.

## Specifications

---

### Construction:

16 ga. steel cabinet, powder coated

### Blower Pkgs (HP):

75, 1.0

### Noise Level (dBA):

66

### Electrical:

.75 HP - 115/1/60, 10 amps.  
1 HP - 115/1/60, 12 amps.  
.75 HP - 220/1/50, 5.6 amps.

### Nominal CFM (in.):

600, 60 Hz.  
500, 50 Hz.

### Weight (lbs.):

203

Diversified Air Systems, Inc.  
Phone: 800-264-8958  
Email: [info@divers-air.com](mailto:info@divers-air.com)  
[www.divers-air.com](http://www.divers-air.com)

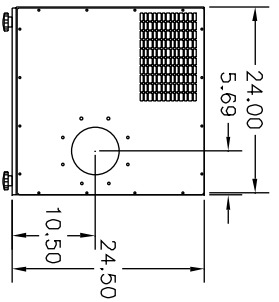

TOP VIEW

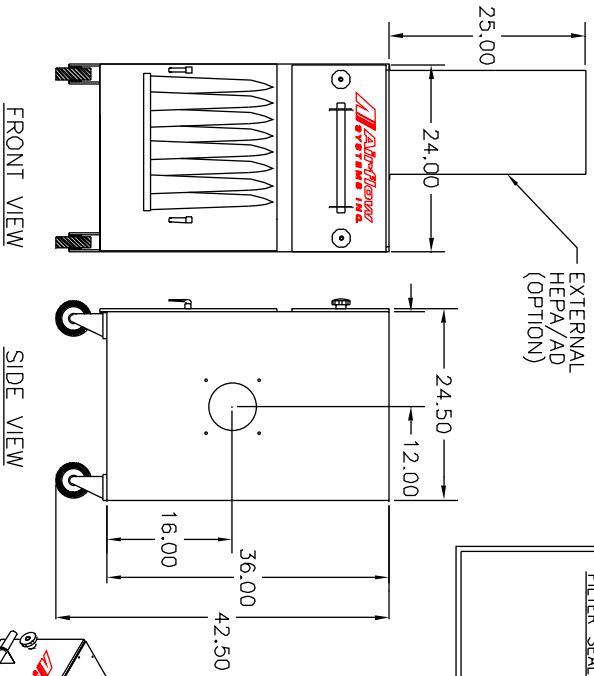

FRONT VIEW

SIDE VIEW

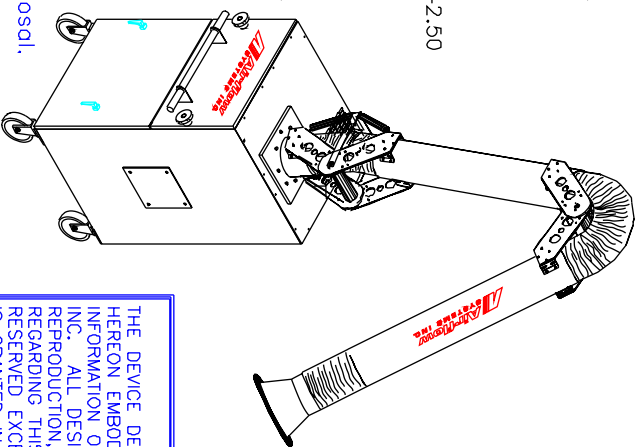

**SPECIFICATIONS:**

**CONSTRUCTION:**

16 Gauge painted steel cabinet with Ultra-Seal™ filter mounting system, side access door to filters and direct drive motor/blower. Includes 7" externally self-supported E-Z ARM™ High Flow Extractor arm, 5" casters, power cord, and on-off switch. Motor wired to junction box outside unit. (Motor starters/disconnects not included. Opt. only).

**WEIGHT:**

203 lbs.

**AIRFLOW:**

560 CFM, std. ; 650 CFM, 1 HP opt.

**NOISE:**

450 CFM with HEPA/AD opt.

**FILTER SEAL:**

Ultra-Seal™ welded picture frame with positive sealing filter locking mechanism for oil main filters, HEPA filter and adsorber modules. (where used). Slide in tracks shall be used for prefilters only.

**PREFILTERS:**

- (1) 2" Aluminum mesh, std.
- (1) Oil mist louver, opt.

**MAIN FILTERS:**

- (1) 28 ft<sup>2</sup> multi-pocket filter, 95% Std.
- (1) 95% cartridge filter, 21 ft<sup>2</sup> followed by an internal 95% D.O.P., opt.
- (1) 95% cartridge filter, 21 ft<sup>2</sup>, followed by an internal 99.97% HEPA filter, opt.
- (1) Polyester shocker bag, opt.

**HEPA OPTIONS:**

- (1) 95% cartridge filter, 21 ft<sup>2</sup>, followed by an internal 99.97% HEPA filter, opt.
- (1) External HEPA filter, 99.97%, opt.
- (1) 95% D.O.P., HEPA, opt.

**AD OPTION:**

- (1) 95% cartridge filter, 21 ft<sup>2</sup>, followed by an 18 lb., refillable, internal adsorber module, opt.
- (1) External od., 25 lb. capacity, opt.

**OTHER OPTIONS:**

- Big wheel kit
- Pressure gauge kit indicates filter changes
- 10" E-Z ARM™ High Flow Extractor
- 8" x 4" dia E-Z ARM™ High Flow Extractor
- Dual 8" x 4" dia E-Z ARM™ High Flow Extractor

\* AFS FILTER EFFICIENCIES BASED ON ASHRAE 52-76 TEST METHOD  
 \*\* ALL FLOWS STANDARD AIR AND FILTERS UNLESS OTHERWISE INDICATED

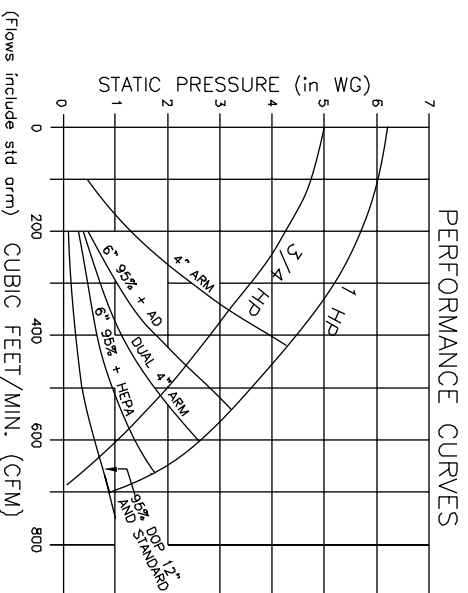

**Diversified Air Systems, Inc.**  
 Phone: 800-264-8958

THE DEVICE DEPICTED AND DESCRIBED  
 HEREON EMBODIES PROPRIETARY  
 INFORMATION OWNED BY AIRFLOW SYSTEMS,  
 INC. ALL DESIGN, MANUFACTURING,  
 REPRODUCING, SALES, AND PATENT RIGHTS  
 REGARDING THIS DEVICE OR DRAWING ARE  
 RESERVED EXCEPT WHERE EXPLICIT RIGHT  
 IS GRANTED IN WRITING.

DRAWN BY CB	TITLE MODEL MINI-PAC (BAG)
DATE 4-12-99	PAGE 1 OF 2
SCALE	DRAWING NO.: MNPCSPEC (39-2104/F)

**NOTES:**  
 Items designated as  are included in this proposal.

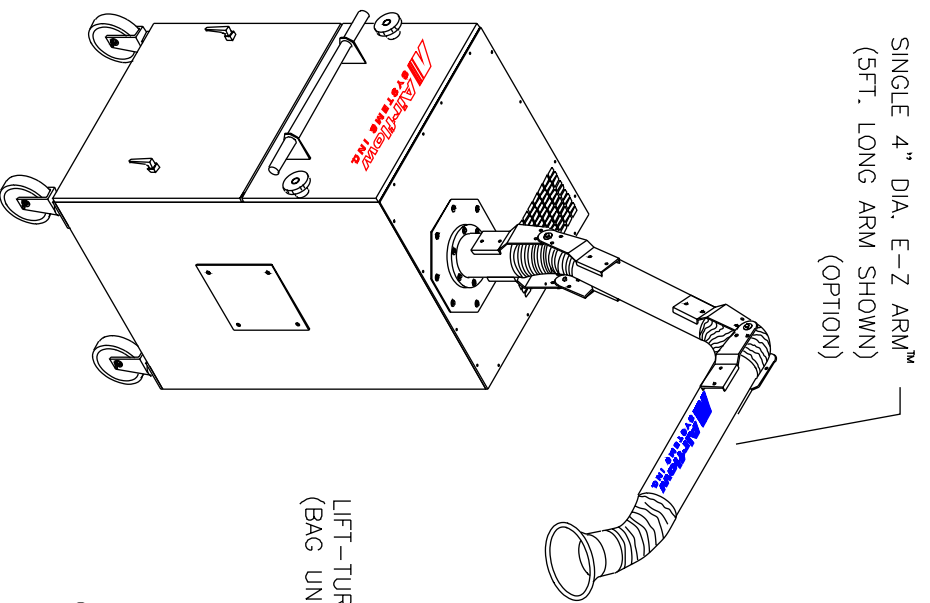

SINGLE 4" DIA. E-Z ARM™  
(5FT. LONG ARM SHOWN)  
(OPTION)

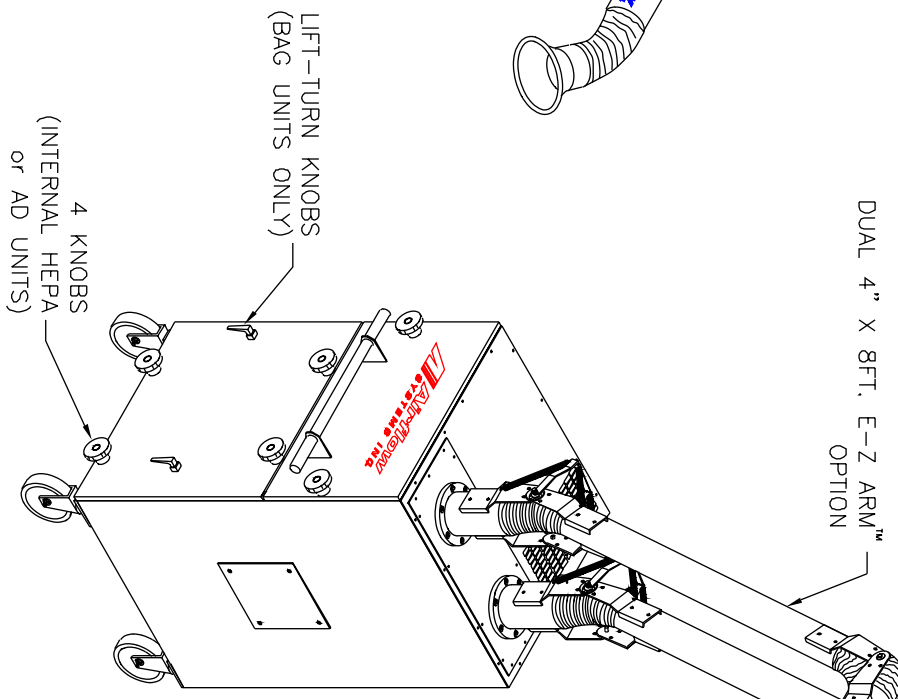

DUAL 4" X 8FT. E-Z ARM™  
OPTION

LIFT-TURN KNOBS  
(BAG UNITS ONLY)

4 KNOBS  
(INTERNAL HEPA  
or AD UNITS)

THE DEVICE DEPICTED AND DESCRIBED  
HEREON EMBODIES PROPRIETARY  
INFORMATION OWNED BY AIRFLOW SYSTEMS,  
INC. ALL DESIGN, MANUFACTURING,  
REPRODUCTION, SALES, AND PATENT RIGHTS  
REGARDING THIS DEVICE OR DRAWING ARE  
RESERVED EXCEPT WHERE EXPLICIT RIGHT  
IS GRANTED IN WRITING.

**Diversified Air Systems, Inc.**  
**Phone: 800-264-8958**

DRAWN BY CB	TITLE MODEL MINI-PAC (BAG)
DATE 4-12-99	PAGE 2 OF 2
SCALE	DRAWING NO.: MNPSPPEC (39-2104/F)

NOTES: