

MP4 Mist Collector

Features & Benefits



- **Exclusive Mist-Plus™ Containment Management System:**
Delivers over 95% filtration efficiency; reduces operating costs by extending maintenance cycles and filter life.
- **Welded steel cabinet:**
Eliminates contaminant escape common with bolt-on panel cabinets.
- **Baked-on powder coat finish:**
Resists harsh industrial environments.
- **Front access filter door:**
Eases filter access; reduces filter maintenance and changeout time.
- **Ultra-Seal® filter mounting:**
Eliminates contaminant bypass of filters.
- **Small footprint:**
Compact, 1.8 ft² cabinet requires minimal floor space; eases machine and wall mounting.
- **Continuous draining:**
Provides for longer filter life.

Dimensions

Width:	16.00"
Height:	35.00"
Depth:	16.00"

Options

- **Pressure Gauge Kit:**
Indicates when filters require cleaning.
- **Pre-Filters:**
1-in. polyester pad.
- **After-Filters:**
99.97% HEPA, 95% DOP and odor modules.
- **Drain Loop Kit:**
Simplifies collection and reclamation on captured oil mist while providing drain line air seal.
- **5-in. Floor Stand:**
Stabilizes floor-mounted units; eases unit and facility maintenance.

Specifications

Construction:

18 ga. zinc coated welded steel, powder coated cabinet

Blower Pkgs (HP):

.75

Noise Level (dBA):

73

Electrical:

.75 HP - 110/220/1/60, 9.8/4.9 amps, std.

.75 HP - 208/230/460/3/60, 2.7-2.6/1.3 amps, opt.

.75 HP - 220/1/50, 5.6 amps.

Nominal CFM (in.):

450, 60 Hz

360, 50 Hz

Weight (lbs.):

105

Diversified Air Systems, Inc.

Phone: 800-264-8958

Email: info@divers-air.com

www.divers-air.com

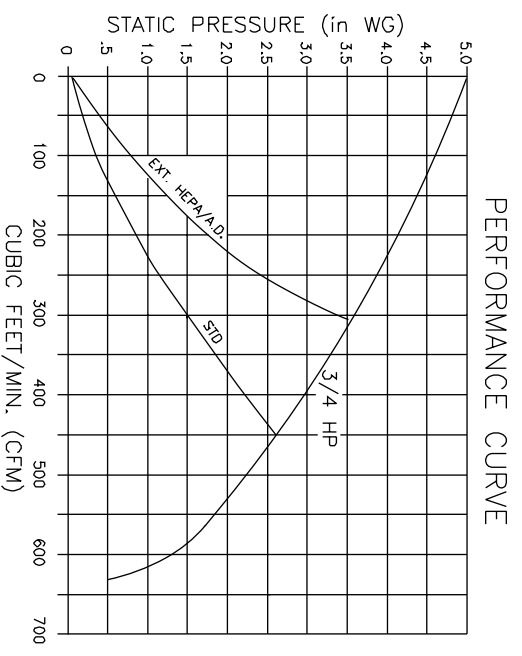
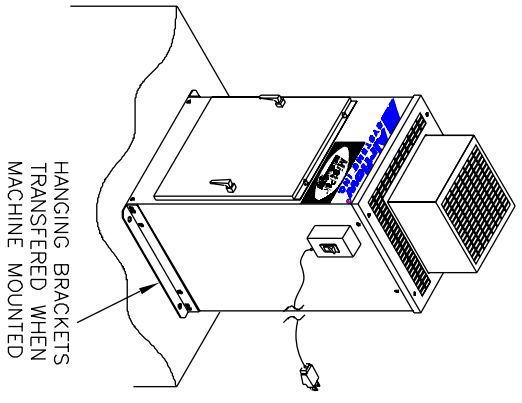
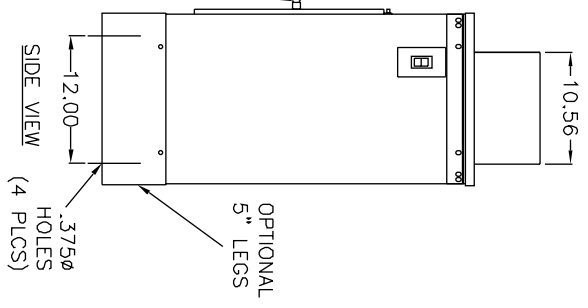
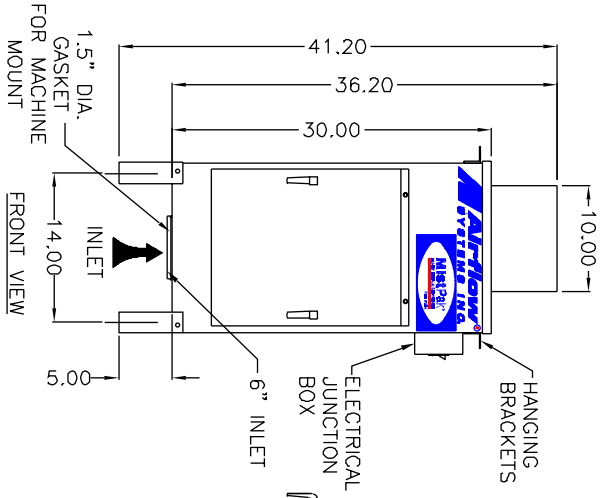
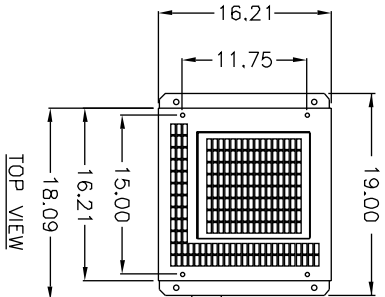

SPECIFICATIONS:

CONSTRUCTION: 18 Gauge steel cabinet finished with a Powder-Cool Finish. Includes Ultra-Seal® filter mounting system, a 2" sump, front access filter door, 6" inlet collar on bottom with a 1.5" diameter rubber gasket for machine mounting, built in exhaust silencer with accoustical lining, on-off switch, and a 6" power cord (115V). Three phase units wired to junction box; circuit and motor overload protection by others.

WEIGHT: 105 lbs.

AIRFLOW: 400 CFM

ELECTRICAL: 3/4 HP, 110/220/1/60, 9.8/4.9 amps, std.
 3/4 HP, 208-230/460/3/60, 2.7-2.6/1.3 amps, opt.

NOISE: 73 dBA

FILTER SEAL: Ultra-Seal® with positive seal filter locking mechanism for main filter.

FIRE SUPPRESSION: Equipment provided by others.

PREFILTERS: (1) 1" Aluminum mesh, std.
 (1) 1" Polyester pad, opt.

MAIN FILTERS: (1) Mist-Plus™ Filter

UNIT EFFICIENCY: 90% Minimum on U.N.C. Oil Mist Test

AFTER FILTERS: (1) 99.97% HEPA, Ext., opt.
 (1) 95% D.O.P., Ext., opt.
 (1) AD Module, Ext., with 2" poly after-filter, opt.

OTHER OPTIONS: Pressure gauge kit (Indicates filter changes.)
 5" Legs
 26" Legs

NOTES:
 Items designated as are included in this proposal.

THE DEVICE DEPICTED AND DESCRIBED HEREON EMBODIES PROPRIETARY INFORMATION OWNED BY AIRFLOW SYSTEMS, INC. ALL DESIGN, MANUFACTURING, REPRODUCTION, SALES, AND PATENT RIGHTS REGARDING THIS DEVICE OR DRAWING ARE RESERVED EXCEPT WHERE EXPLICIT RIGHT IS GRANTED IN WRITING.

Diversified Air Systems, Inc.
 Phone: 800-264-8958

DRAWN BY: CB
 DATE: 7-2-01
 SCALE:

TITLE: MODEL MP04
 PAGE 1 OF 3
 DRAWING NO.: MP04SPEC (73-3214/E)

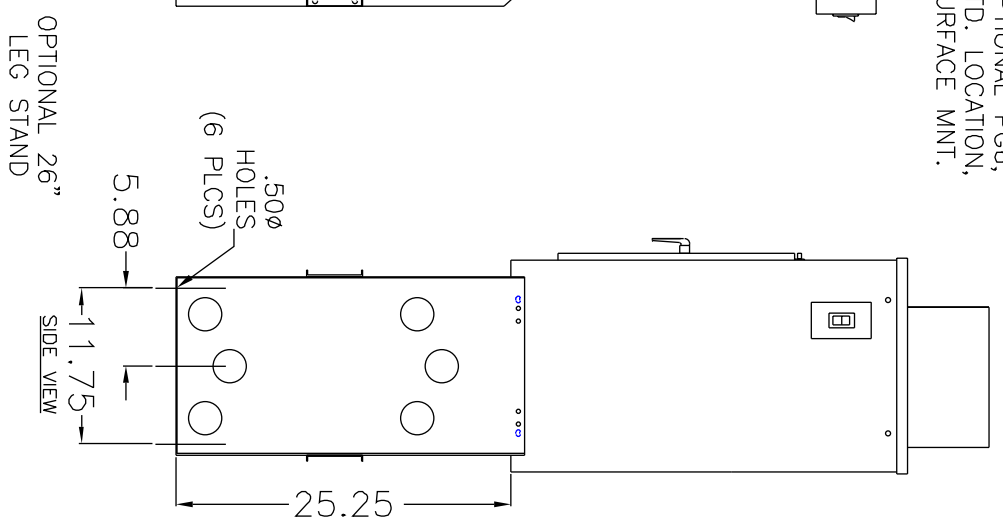
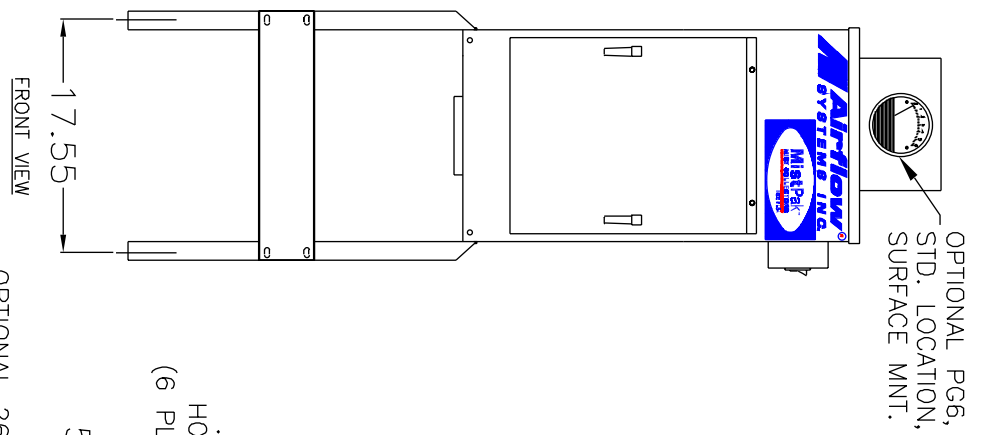
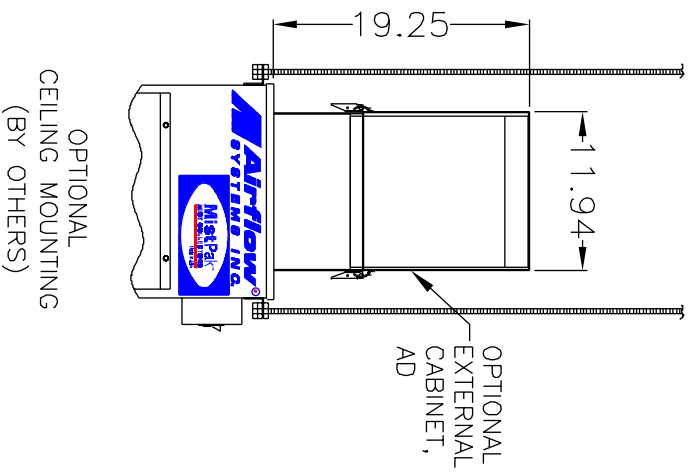
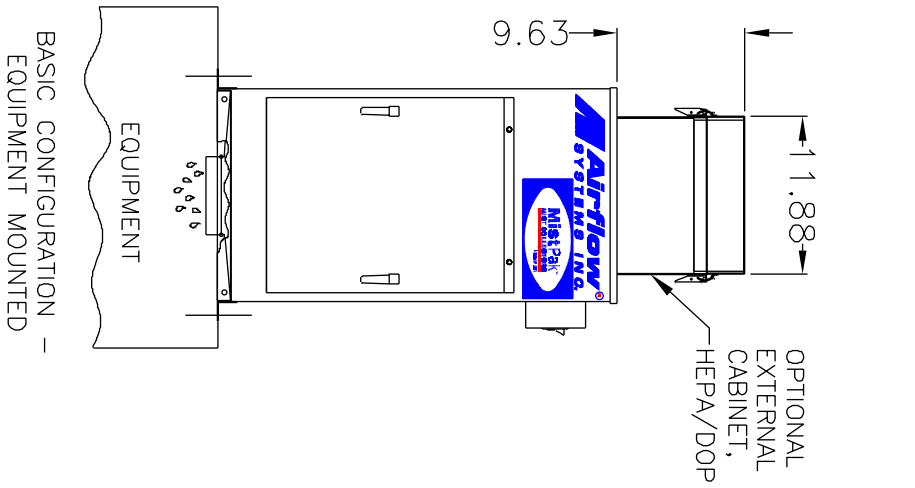

THE DEVICE DEPICTED AND DESCRIBED HEREON EMBODIES PROPRIETARY INFORMATION OWNED BY AIRFLOW SYSTEMS, INC. ALL DESIGN, MANUFACTURING, REPRODUCTION, SALES, AND PATENT RIGHTS REGARDING THIS DEVICE OR DRAWING ARE RESERVED EXCEPT WHERE EXPLICIT RIGHT IS GRANTED IN WRITING.

Diversified Air Systems, Inc.
Phone: 800-264-8958

DRAWN BY CB	TITLE MODEL MP04
DATE 7-2-01	PAGE 2 OF 3
SCALE	DRAWING NO.: MP04SPEC (73-3214/E)

NOTES:

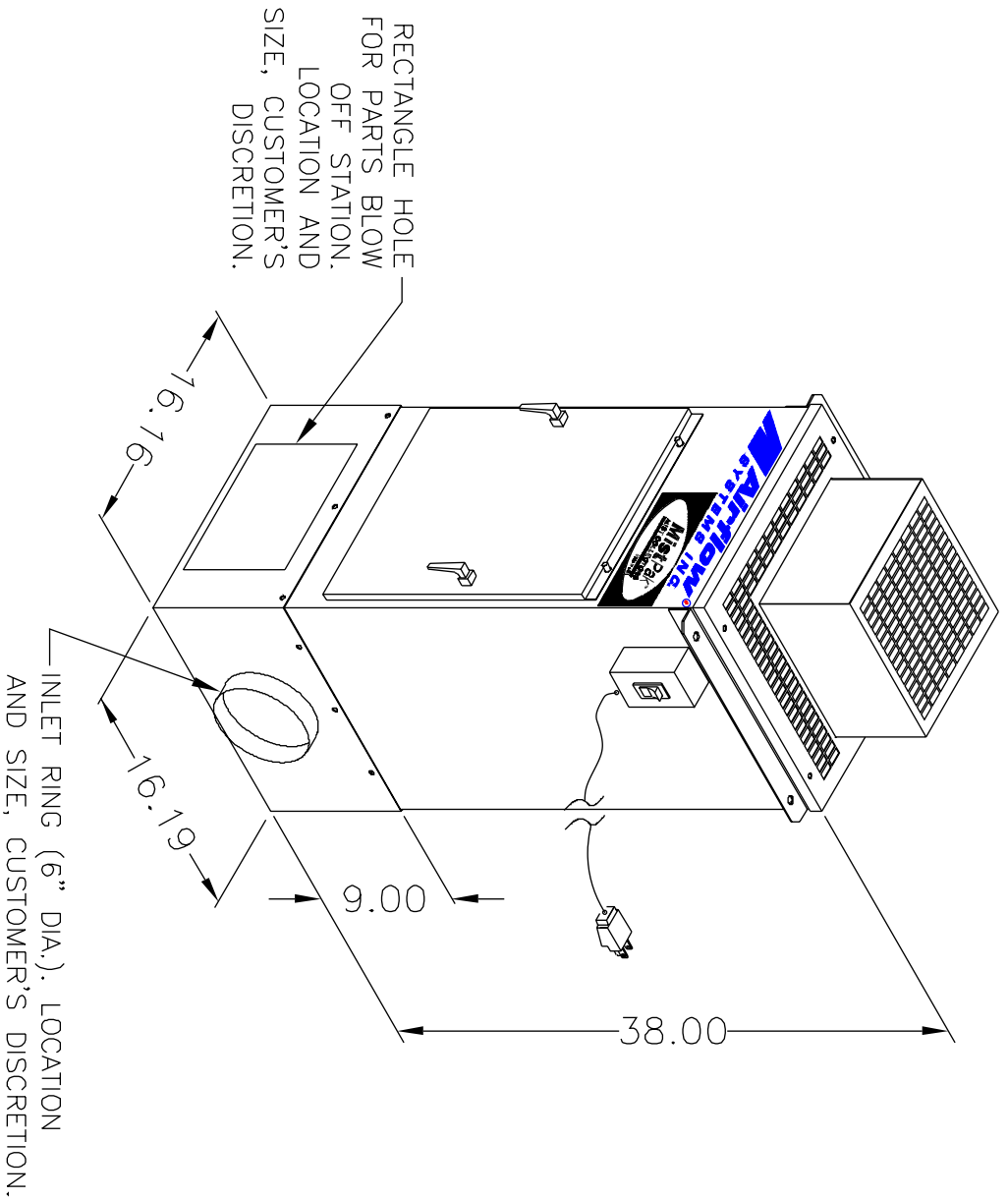

NOTES:

THE DEVICE DEPICTED AND DESCRIBED HEREON EMBODIES PROPRIETARY INFORMATION OWNED BY AIRFLOW SYSTEMS, INC. ALL DESIGN, MANUFACTURING, REPRODUCTION, SALES, AND PATENT RIGHTS REGARDING THIS DEVICE OR DRAWING ARE RESERVED EXCEPT WHERE EXPLICIT RIGHT IS GRANTED IN WRITING.

Diversified Air Systems, Inc. Phone: 800-264-8958	
DRAWN BY CB	TITLE MODEL MP04
DATE 7-2-01	PAGE 3 OF 3
SCALE	DRAWING NO.: MP04SPEC (73-3214/E)