

PCH-2 Portable Dust Collector



Features & Benefits

- **Complete, self-contained unit:**
Includes 7-ft. E-Z Arm® High Flow Extractor Arm, blower, and filter cartridge.
- **Direct-drive blower:**
Higher static pressure, longer filter life and greater reliability; non-sparking; no belts or pulleys to replace.
- **Non-electrostatic operation:**
High reliability, low maintenance.
- **Ultra-Seal® filter mounting:**
Eliminates contaminant bypass of filters.
- **Vibra-Pulse® Filter Cleaning System:**
Cleans filters 75% more effectively than reverse pulse systems.
- **Low profile cabinet:**
Low center of gravity for easy maneuverability and arm positioning.
- **Heavy-Duty, 25-ft. power cord:**
Maximizes system portability and positioning during operation.

Dimensions

Width:	24.00"
Height:	28.00"
Depth:	41.00"

Options

- **Pressure Gauge Kit:**
Indicates when filters require cleaning.
- **10-ft. or 14-ft. E-Z Arm® High Flow Extractor Arm:**
Replaces standard 7-ft. E-Z Arm® for additional reach and peak system performance.
- **Cartridge Media:**
Available for specific applications.
- **After-Filters:**
99.97% HEPA, 95% DOP and odor modules.
- **65-Watt Halogen Light Kit:**
Improves worker visibility.

Specifications

Construction:

12/14/16 ga. welded steel, powder coated cabinet

Blower Pkgs (HP):

1.5, 3.0

Noise Level (dBA):

76 standard
82/74, 3 HP with silencer

Electrical:

1.5 HP - 115/208-230/1/60, 15/7.9-7.5/2.3 amps, std.,
3.0 HP - 208-230/460/3/60, 4.9-4.6/2.3 amps. opt.
1.5 HP - 220/1/50

Nominal CFM (in.):

800/1200, 60 Hz
900, 50 Hz

Weight (lbs.):

320

SPECIFICATIONS:

CONSTRUCTION:

12/14/16 Gauge steel cabinet finished with Powder-Cool Finish. Includes a 10 gallon external dust drawer, 10" E-Z Arm High Flow Extractor arm, removable end cap for easy access to filters, removable panel for easy access to direct drive motor, blower, 8" casters, 25' 12 Ga. power cord, and on-off switch. Motor wired to junction box outside unit for 3 phase. Acoustical lining standard in blower compartment. Vibro-Pulse cleaning standard.

MAIN FILTERS:

- (2) CLEAN-2 Filter cartridge, 16"Dx12", Std.
- (2) Cartridge, FIBERDUST, Opt.
- (2) Cartridge, Spark Resistant, Opt.
- (2) Cartridge, Sounbond - H0, Opt.
- (2) Cartridge, CleanPlus double treated fire retardant, Opt.

WEIGHT:

320 lbs.

AIRFLOW:

1000 CFM with std. 1.5 HP motor
1200 CFM with opt. 3 HP motor

AFTER FILTERS:

- (1) External HEPA filter, 99.97%
- (1) External DOP filter, 95%
- (1) External adsorber, 25 lb. capacity
- (1) Activated Charcoal
- (1) Purafil

NOISE:

76 dBA - 1.5 HP
82 dBA / 74 with silencer - 3 HP

ELECTRICAL:

- 1.5 HP 115/208-230/1/60, 15/7.9-7.5 amps, std.
- 1.5 HP 208-230/460 /3/60, 4.9-4.6/2.3 amps, opt
- 3 HP 208-230/460/3/60, 8.4-8.0/4.0 amps opt.

OTHER OPTIONS:

- Pressure gauge kit indicates filter changes
- 14" E-Z Arm High Flow Extractor
- Dual 10" E-Z Arm High Flow Extractors
- Regulator
- Silencer (Adds 3" to depth of unit)

FIRE SUPPRESSION:

Equipment provided by others.

SPECIAL NOTES:

Compressed air filter provided by others.

* AFS FILTER EFFICIENCIES BASED ON ASHRAE 52-76 TEST METHOD

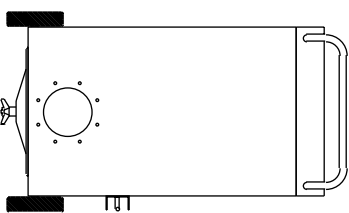

TOP VIEW
(SHOWN LESS ARM)

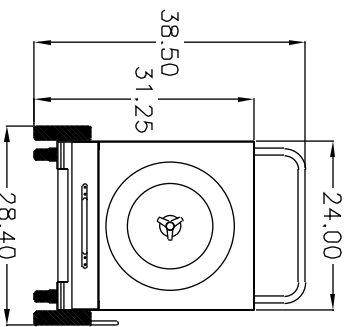

BACK VIEW
(SHOWN LESS ARM)

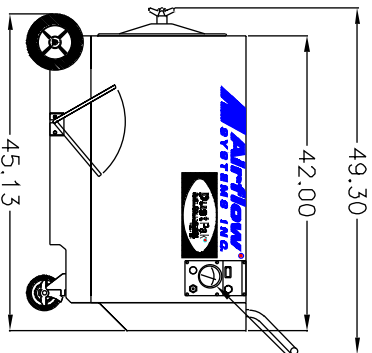

SIDE VIEW
(SHOWN LESS ARM)

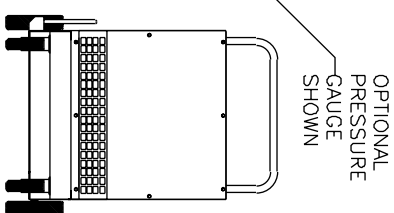

FRONT VIEW
(SHOWN LESS ARM)

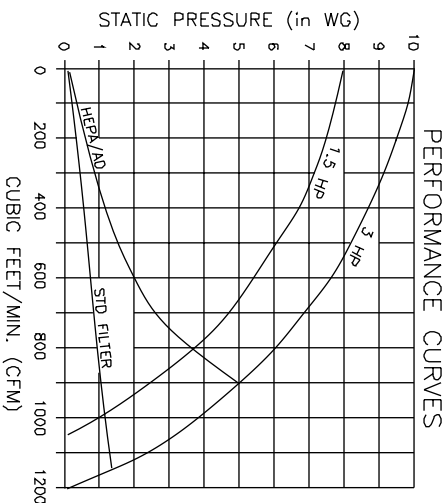
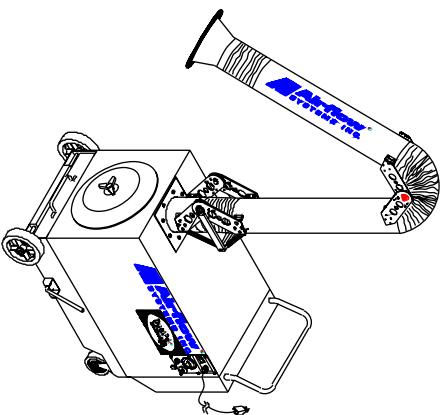

NOTES:

Items designated as are included in this proposal.

THE DEVICE DEPICTED AND DESCRIBED HERON EMBODIES PROPRIETARY INFORMATION OWNED BY AIRFLOW SYSTEMS, INC. ALL DESIGN, MANUFACTURING, REPRODUCTION, SALES, AND PATENT RIGHTS REGARDING THIS DEVICE OR DRAWING ARE RESERVED EXCEPT WHERE EXPLICIT RIGHTS IS GRANTED IN WRITING.

Diversified Air Systems, Inc.
Phone: 800-264-8958

DRAWN BY CB	TITLE MODEL PCH2 (CARTRIDGE)
DATE 10-6-00	PAGE 1 OF 2
SCALE	DRAWING NO.: PCH2SPEC (52-2878/C)

EXTERNAL
HEPA/AD/DOP OPTION

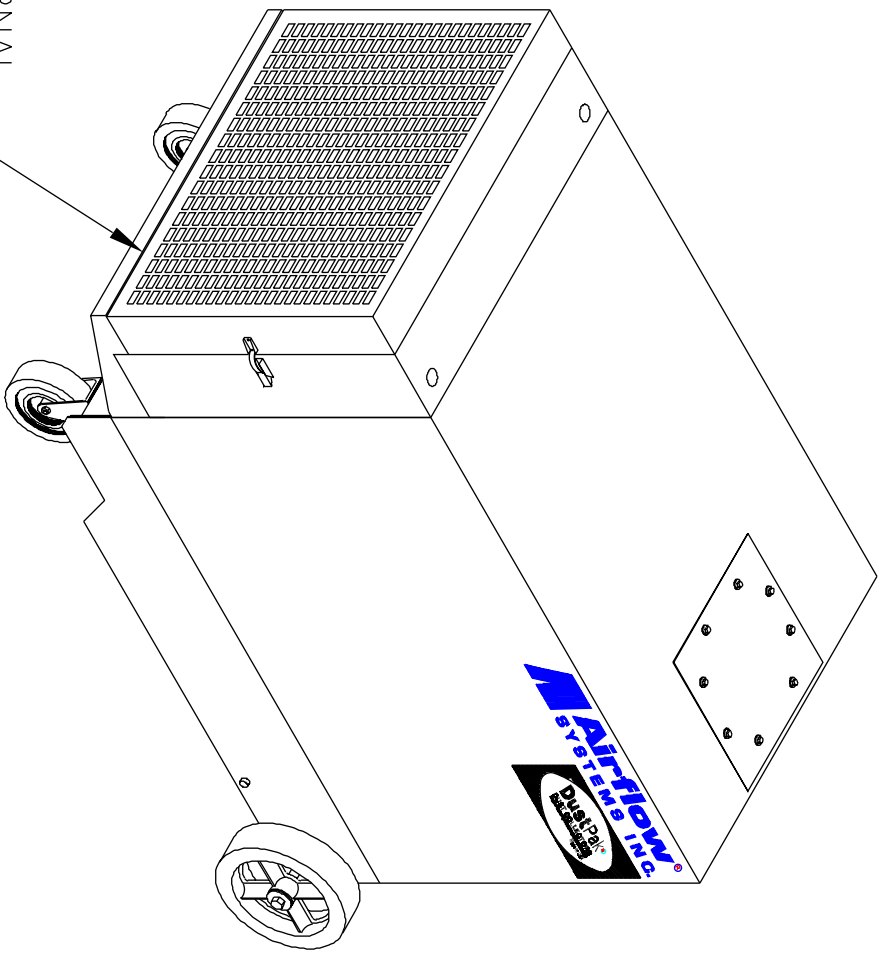

THE DEVICE DEPICTED AND DESCRIBED
HEREON EMBODIES PROPRIETARY
INFORMATION OWNED BY AIRFLOW SYSTEMS,
INC. ALL DESIGN, MANUFACTURING,
REPRODUCTION, SALES, AND PATENT RIGHTS
REGARDING THIS DEVICE OR DRAWING ARE
RESERVED EXCEPT WHERE EXPLICIT RIGHT
IS GRANTED IN WRITING.

Diversified Air Systems, Inc. Phone: 800-264-8958	
DRAWN BY PG	TITLE MODEL PCH2
DATE 10-6-00	PAGE 2 OF 2
SCALE	DRAWING NO.: PCH2SPEC (52-2878/C)

NOTES: