



Shown With Optional
Caster Kit

Dimensions

Width:	48.00"
Height:	122.00"
Depth:	24.00"

Options

- **Pressure Gauge Kit:**
Indicates when filters require cleaning.
- **Cartridge Media:**
For specific applications.
- **After-Filters:**
99.97% HEPA, 95%, and odor-control modules.
- **Welding Package Kit:**
Includes special cartridges and non-reflective inlet.
- **12-in. Side Shields**
Optimum depth for direct contaminant intake and increased collection efficiency.
- **Factory-Installed Casters:**
Provides portability, increases system versatility.
- **Casters:**
Improves maneuverability and productivity.

PowerBooth™ Dust Control System Features & Benefits

- **Self-contained system:**
Eliminates costly ductwork and the need for a separate dust collection system.
- **5 HP direct-drive blower:**
Improves collection efficiency, increases reliability.
- **High efficiency filter media:**
Compact, high-density cartridge filter provides maximum effectiveness; filter changes easily without tools.
- **Industry's largest inlet grille area:**
Keeps contaminants away from workers' breathing zone; diffuser design reduces air velocity, reducing operating costs and premature filter loading.
- **Large-volume dust drawer:**
Provides for high-volume collection, extends maintenance cycles.
- **Vibra-Pulse® Filter Cleaning System:**
Cleans filters 75% more effectively than reverse pulse systems.
- **Auto-Clean off-line filter cleaning:**
Automatically cleans filters when unit is shut off.
Built in damper to prevent dust escape during cleaning.

Specifications

Construction:

16 ga. steel cabinet, powder coated

Blower Pkg (HP):

5.0

Noise Level (dBA):

77

Electrical:

5.0 HP - 208/230/460/3/60, 13-12/6 amps, std;

3.0 HP - 190/380/3/50 11.3/5.65

Nominal CFM (in.):

4500, 60 Hz

3600, 50 Hz

Weight (lbs.):

800

Diversified Air Systems, Inc.

Phone: 800-264-8958

Email: info@divers-air.com

www.divers-air.com

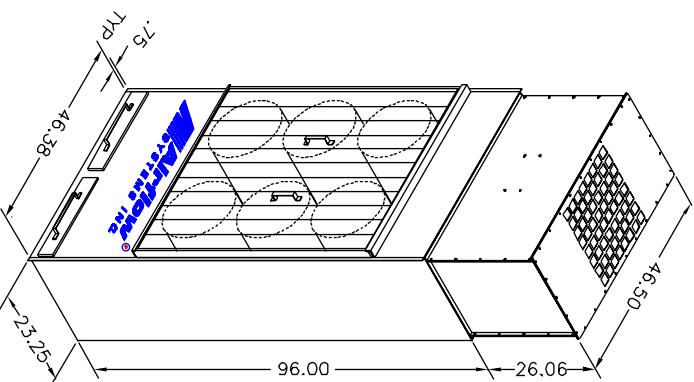
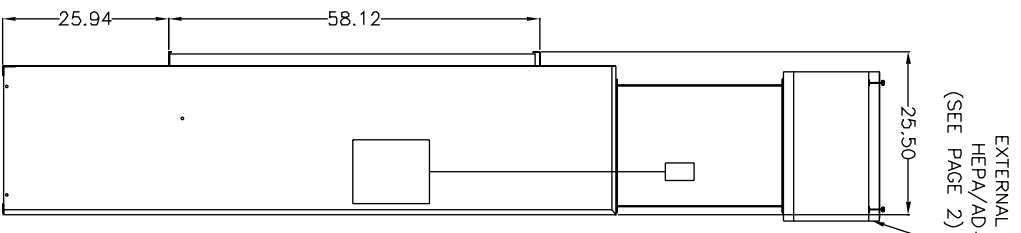
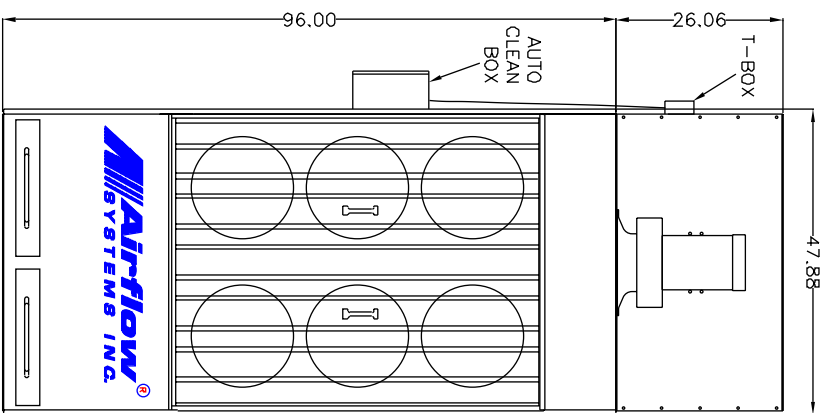
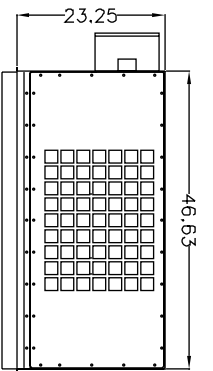

SPECIFICATIONS:

CONSTRUCTION: 16 Ga. welded zinc coated steel cabinet, finished with Powder-Coat finish. Includes removable access panels to filters and motor, direct drive ball bearing, BL blower, Auto clean Vibro-Pulse® filter cleaning system and on acoustic lined inlet plenum and blower compartment. Motor wired to junction box outside unit. Motor starters/disconnects NOT included.

WEIGHT: 680 lbs.

AIRFLOW (STD AIR): 4500 CFM W/HEPA or V-Bank 4000 CFM

NOISE: 77dBA

ELECTRICAL: SHP 208-230/460/3/60, 13-12/6.0 amps, std. SHP 230/1/60, 19.5 amps, opt.

MAIN FILTERS: (6) 150 ft³ CLEAN 2® cartridges, std. (6) 75 ft³ Fiber Dust® cartridges, opt.

AFTER FILTERS: (6) Spunbond cartridges, opt. (2) HEPA filter, 99.97%

AD OPTION: (4) 25 lb. adsorber modules, refillable.

OTHER OPTIONS: Pressure gauge kit indicates filter changes, filters. Welding Application, + (6) UltraClean-Plus filters.

FIRE SUPPRESSION: Manual clean in place of Vibro-pulse. Equipment provided by others.

PERFORMANCE CURVES

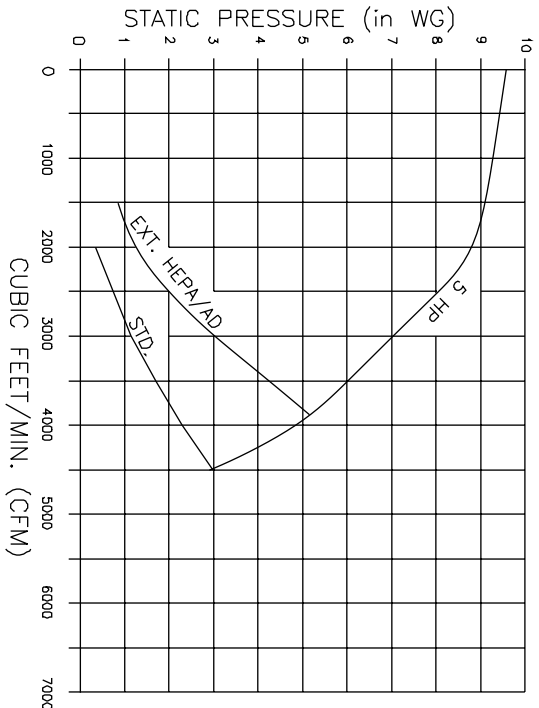

NOTES:

THE DEVICE DEPICTED AND DESCRIBED HEREON EMBODIES PROPRIETARY INFORMATION OWNED BY AIRFLOW SYSTEMS, INC. ALL DESIGN, MANUFACTURING, REPRODUCTION, SALES, AND PATENT RIGHTS REGARDING THIS DEVICE OR DRAWING ARE RESERVED EXCEPT WHERE EXPLICIT RIGHT IS GRANTED IN WRITING.

Diversified Air Systems, Inc.
Phone: 800-264-8958

DRAWN BY: JRS	TITLE: POWER BOOTH
DATE: 12-7-99	PAGE: 1 OF 2
SCALE: NTS	DRAWING NO.: PBTHSPEC (81-2424/B)

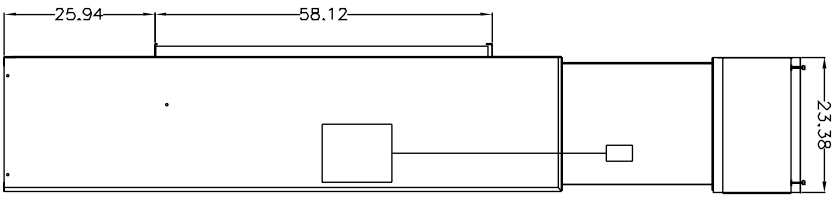
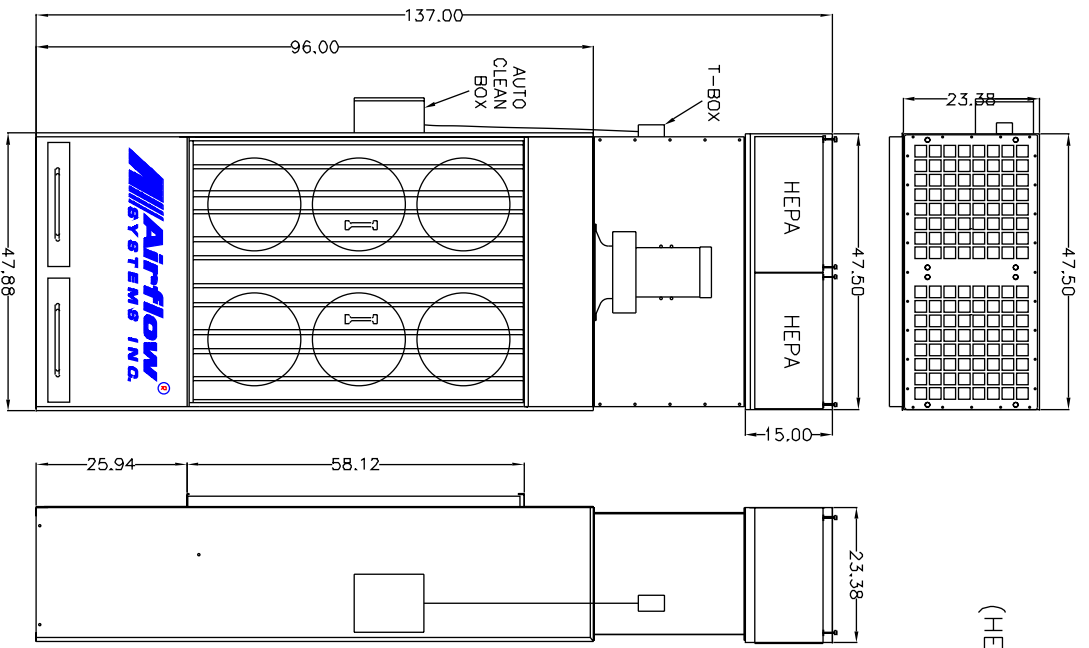

EXTERNAL HEPA
OR AD OPTION
(HEPA FILTERS SHOWN)

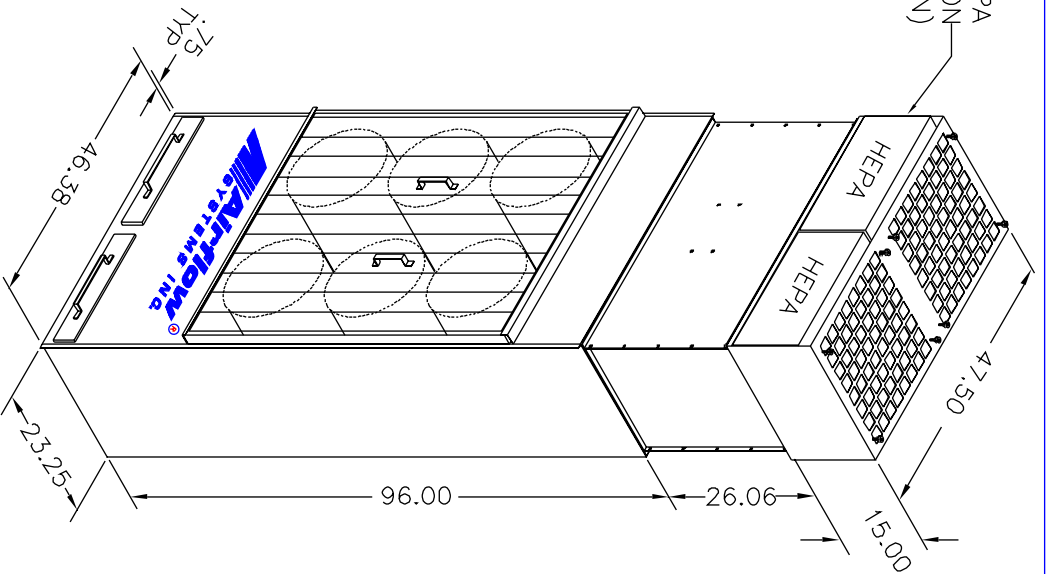

NOTES:

THE DEVICE DEPICTED AND DESCRIBED
HEREON EMBODIES PROPRIETARY
INFORMATION OWNED BY AIRFLOW SYSTEMS,
INC. ALL DESIGN, MANUFACTURING,
REPRODUCTION, SALES, AND PATENT
RIGHTS REGARDING THIS DEVICE OR DRAWING ARE
RESERVED EXCEPT WHERE EXPLICIT RIGHT
IS GRANTED IN WRITING.

Diversified Air Systems, Inc. Phone: 800-264-8958	
DRAWN BY JRS	TITLE POWER BOOTH
DATE 12-7-99	PAGE 2 OF 2
SCALE NTS	DRAWING NO.: PBTHSPEC (81-2424/B)

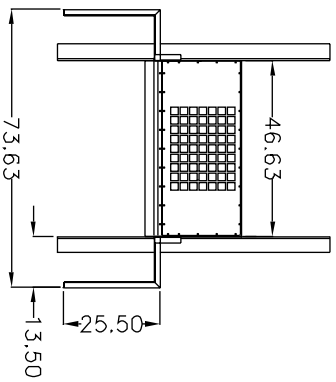

TOP VIEW

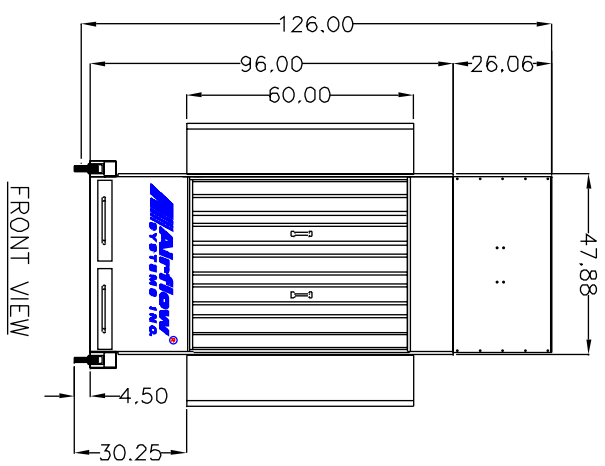

FRONT VIEW

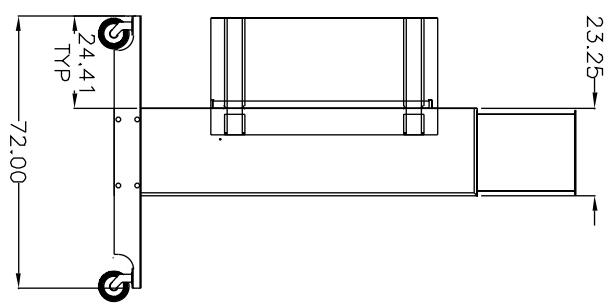

SIDE VIEW

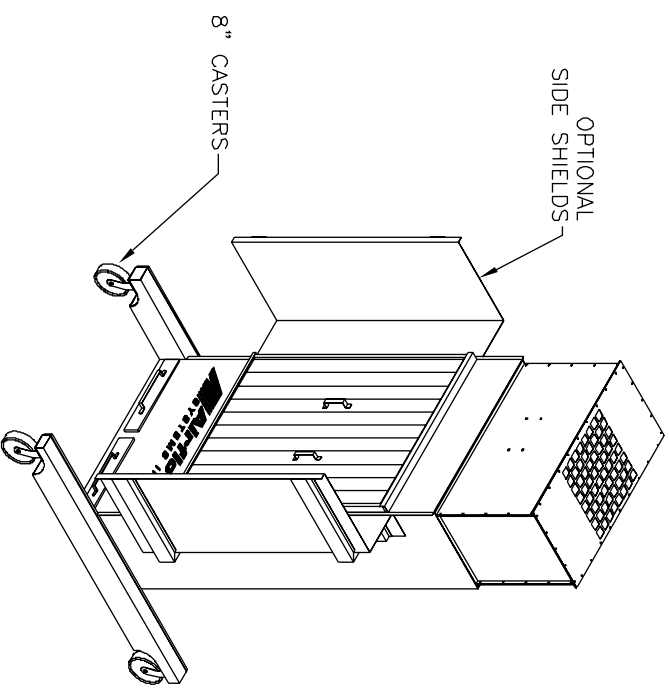

SPECIFICATIONS:

CONSTRUCTION: 16 Ga. welded zinc coated steel cabinet, finished with a two part chemical and oil resistant paint. Removable access panels to filters and motor. Direct drive ball bearing BL blower. Automatic Vibro-pulse cleaning. Motor wired to junction box outside unit. Motor starters/disconnects NOT included.

WEIGHT: 800 lbs.

AIRFLOW: 4500 CFM (STD AIR) 4000 CFM W/HEPA or V-Bank

NOISE: 77dBA

ELECTRICAL: 5HP 208-230/460/3/60, 13-12/6.0 amps, std. 5HP 230/1/60, 19.5 amps, opt.

* AFS FILTER EFFICIENCIES BASED ON ASHRAE 52-76 TEST METHOD

MAIN FILTERS: (6) 150 ft² CLEAN 2 cartridges, std. (6) 75 ft² Fiber Dust cartridges, opt. (6) Spanbond cartridges, opt.

AFTER FILTERS: (2) HEPA filter, 99.97%

AD. OPTION: (4) 25 lb. adsorber modules, refillable.

OTHER OPTIONS: Pressure gauge kit indicates filter changes. Welding Application, opt. Manual clean in place of Vibro-pulse. Side shields. PB06. POWERBOOTH™ dust collector for use in customer built control room. Moves valve box to front of POWERBOOTH™ and requires remote mounted control box (CONTROLLER option). Order required number of POWERBOOTH dust collectors with PB06 option and (1) CONTROLLER option.

NOTES:
CAUTION: DO NOT ROLL UNIT ON INCLINES GREATER THAN 10° DUE TO POSSIBILITY OF TIP OVER.

THE DEVICE DEPICTED AND DESCRIBED HEREON EMBODIES PROPRIETARY INFORMATION OWNED BY AIRFLOW SYSTEMS, INC. ALL DESIGN, MANUFACTURING, REPRODUCTION, SALES, AND PATENT RIGHTS REGARDING THIS DEVICE OR DRAWING ARE RESERVED EXCEPT WHERE EXPLICIT RIGHT IS GRANTED IN WRITING.

Diversified Air Systems, Inc.
Phone: 800-264-8958

DRAWN BY: JRS
DATE: 5-17-00
SCALE: NTS

TITLE: PORTABLE POWER BOOTH
DRAWING NO.: PPB6SPC (81-2672/A)