

1200 VOM Mist Collector



Features & Benefits

- **High capacity source capture:**
Simplifies OSHA compliance.
- **Direct-drive blower:**
Higher static pressure, longer filter life and greater reliability; non-sparking; no belts or pulleys to replace.
- **Non-electrostatic operation:**
High reliability, low maintenance.
- **Ultra-Seal® filter mounting:**
Eliminates contaminant bypass of filters.
- **Vertical design with small footprint:**
Eases installation, aids draining.

Dimensions

Width:	25.00"
Height:	44.00"
Depth:	16.00"

Options

- **Silencer:**
Reduces noise by 6 dBA.
- **Chevron® Mist Eliminator:**
Effectively removes moisture; improves filtration effectiveness and extends filter life.
- **HEPA After-Filter Module:**
Includes 95% efficiency multi-pocket filter, followed by 99.97% DOP efficiency HEPA filter.
- **DOP/Heavy Smoke Filter:**
Provides 95% efficiency.
- **Attached or Separate Pickup Arms.**

Specifications

- **Construction:**
16 ga. steel, powder coated cabinet
- **Blower Pkgs (HP):**
1.0, 1.5
- **Noise Level (dBA):**
72, 1.0 HP
- **Electrical:**
1.0 HP - 220/1/50, 6.6 amps.
1.5 HP - 208/230/460/3/60, 4.8/2.4 amps
- **Normal CFM (in.):**
1100, 60 Hz
800, 50 Hz
- **Weight (lbs.):**
120

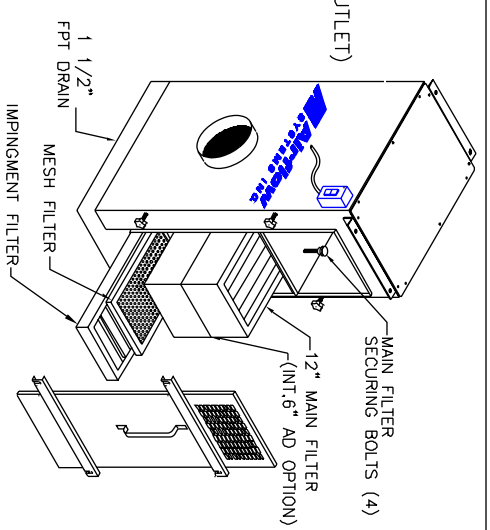
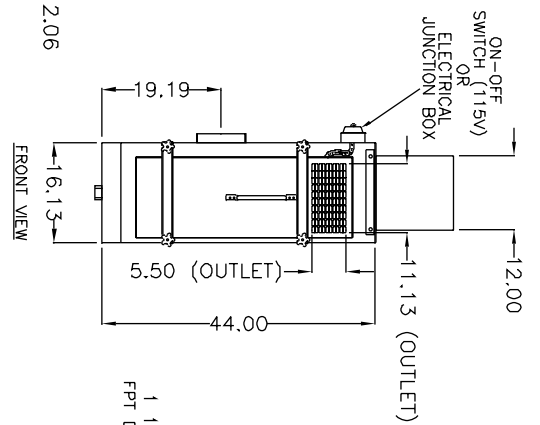
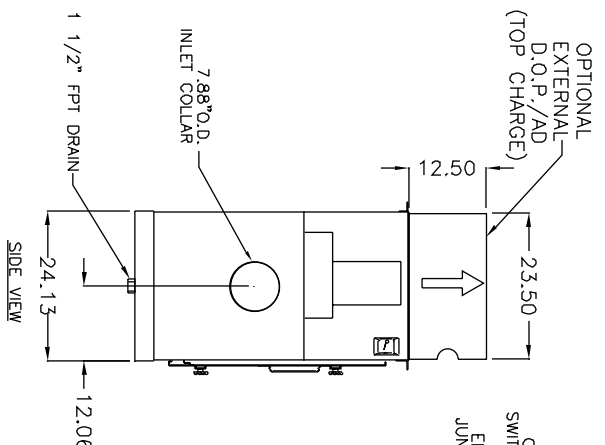
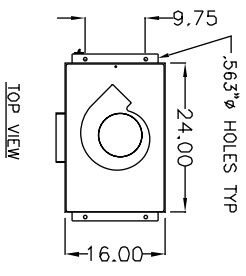

SPECIFICATIONS:

CONSTRUCTION:

16 Gauge all welded cabinet, zinc coated steel, finished with 2 part chemical and oil resistant paint. Includes removable front access door, intake plenum with integral 3" sump and drain, and Ultra-Seal™ filter frame. Includes brackets for rod hanging of unit. Direct-drive, hi-pressure motor/blower. Motor starters/disconnects not included.

WEIGHT:

170 lbs.

AIRFLOW:

1200 CFM

ELECTRICAL:

- 1 HP 115/230/1/60, 14.0/7.0 amps, std.
- 1.5 HP 208-230/460/3/60/50, 4.2-4.8/2.4 amps, opt.
- 115V AC wired with cord and switch; others terminated at J-box on unit exterior.
- Direct-drive and high pressure motor/blower-std. and high pressure.

NOISE:

72 DBA STD.

FILTER SEAL:

Ultra-Seal™ welded picture frame with positive sealing filter locking mechanism for all main filters, HEPA filter, and adsorber modules (where used). Equipment provided by others.

PREFILTERS:

- (1) 2" impingement, std.
- (1) 2" metal mesh, opt.
- (1) 4" Chevron™ mist eliminator, opt.

MAIN FILTERS:

- (1) 2" metal mesh, std.
- (1) 12" main cartridge, 95%, std.
- (1) 6" 95% D.O.P. preceded by 6" cartridge, opt.
- (1) 12" internal HEPA, 99.97%, opt.
- (1) External HEPA, 99.97% (top discharge), opt.
- (1) 2" charcoal, opt.

AFTER FILTERS:

- (1) Internal 6"-bank refillable adsorber module, 12 lb. capacity, preceded by 6" cartridge filter, 95%, w/2" pleat after filter.
- (1) External D.O.P. or AD (top discharge)

AD OPTION:

- Pressure gauge kit, indicates filter changes
- Positioner 5", 8"
- Silencer
- Stand
- Drain trap

OTHER OPTIONS:

* AFS FILTER EFFICIENCIES BASED ON ASHRAE 52-76 TEST METHOD

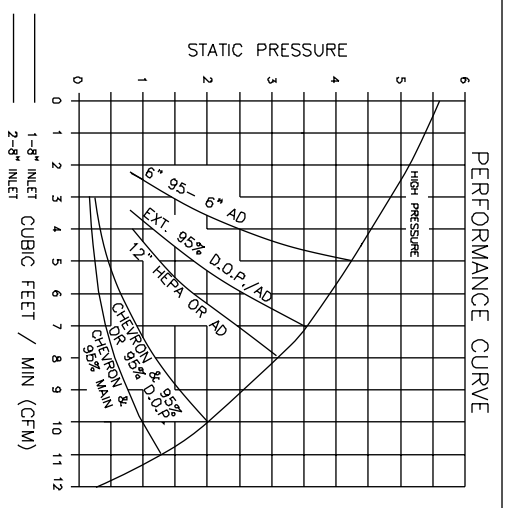

Diversified Air Systems, Inc.
 Phone: 800-264-8958

THE DEVICE DEPICTED AND DESCRIBED HEREON EMBODIES PROPRIETARY INFORMATION OWNED BY AIRFLOW SYSTEMS, INC. ALL DESIGN, MANUFACTURING, REPRODUCTION, SALES, AND PATENT RIGHTS REGARDING THIS DEVICE OR DRAWING ARE RESERVED EXCEPT WHERE EXPLICIT RIGHT IS GRANTED IN WRITING.

DRAWN BY: JRS
 DATE: 5-9-00
 SCALE: _____
 TITLE: MODEL 1200V.2 VOM
 PAGE 1 OF 2
 DRAWING NO.: 1200V2SP (14-2658/L)

NOTES:
 ITEMS DESIGNATED AS ARE INCLUDED IN THIS PROPOSAL.

STAND OPTION

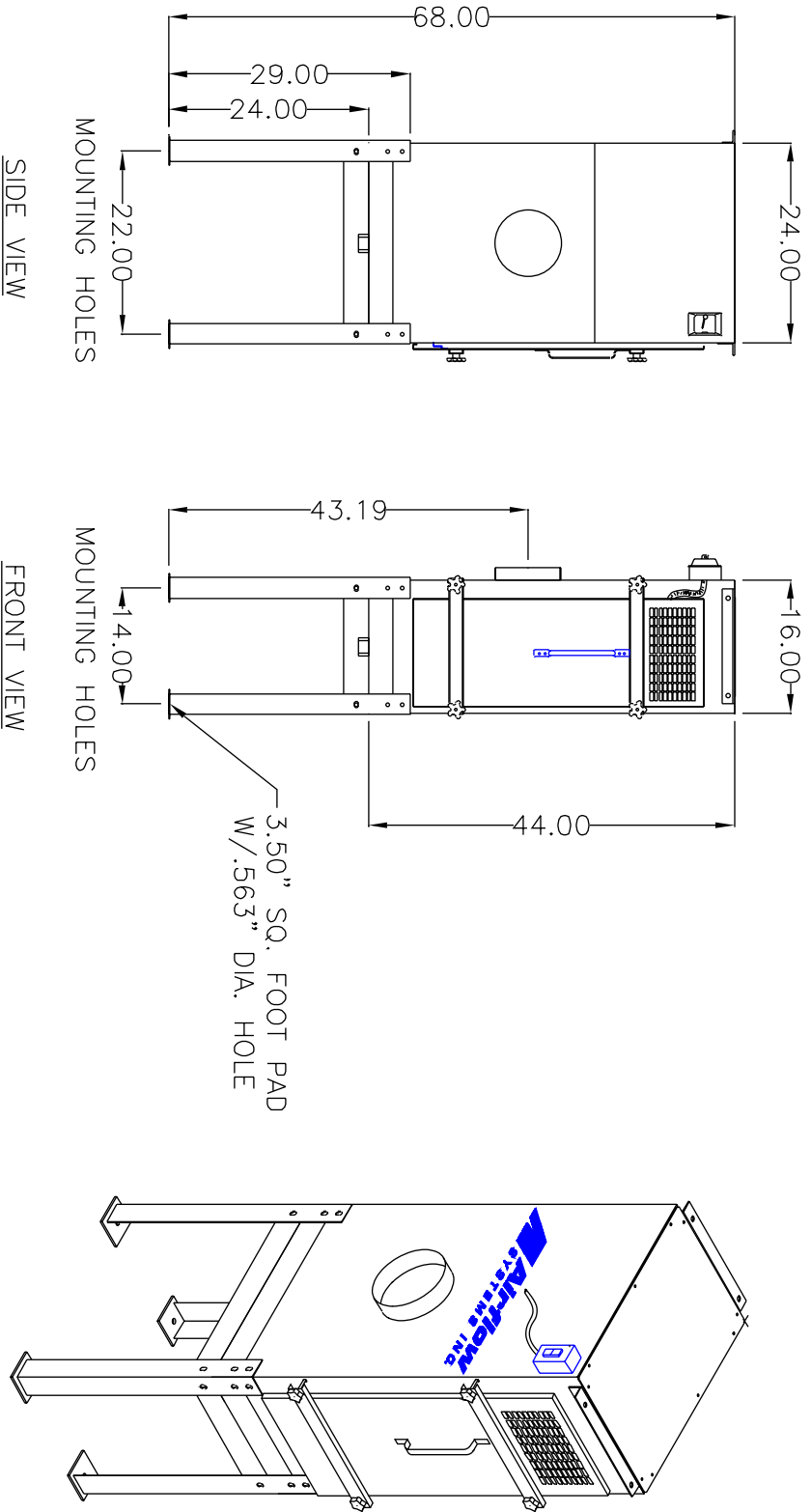

NOTES:

THE DEVICE DEPICTED AND DESCRIBED
HEREON EMBODIES PROPRIETARY
INFORMATION OWNED BY AIRFLOW SYSTEMS,
INC. ALL DESIGN, MANUFACTURING,
REPRODUCTION, SALES, AND PATENT RIGHTS
REGARDING THIS DEVICE OR DRAWING ARE
RESERVED EXCEPT WHERE EXPLICIT RIGHT
IS GRANTED IN WRITING.

Diversified Air Systems, Inc.
Phone: 800-264-8958

DRAWN BY JRS	TITLE MODEL 1200V.2 VOM
DATE 5-9-00	PAGE 2 OF 2
SCALE	DRAWING NO.: 1200V2SP (14-2658/L)