

**SPECIFICATIONS:**

**CONSTRUCTION:** 16 Ga. welded, zinc coated, steel cabinet, finished with a Powder-Coat finish. Includes removable panels for access to filters, lifting angles on top of unit, and a spark resistant, direct drive B.I. blower in an acoustic lined blower compartment. Motor starters/disconnects NOT included.

**WEIGHT:** 520 lbs.

**AIRFLOW:** 5000 CFM  
 (STD AIR) 4500 CFM W/HEPA or V-Bank

**NOISE:** 77dBA

**ELECTRICAL:**  3HP 208-230/460/3/60, 7.8-7.2/4 amps, std.  
 3HP 230/1/60, 11.7 amps, opt.

**FIRE SUPPRESSION:** Equipment provided by others.

**PREFILTERS:**  (2) 24 x 72 x 2 Poly, opt.

**MAIN FILTERS:**  (12) 24 x 24 x 6 MERV 11, 42 ft.<sup>2</sup> each, std.  
 (36) 24 x 24 x 2 MERV 11, opt.  
 (12) 2" MERV 11 and (12) 4" 30% pleat, opt.  
 (12) 2" MERV 11 and (12) 4" MERV 14, washable synthetic, opt.

**AD OPTION:**  (12) 2" MERV 11 and (12) 3" 30 lb. AD modules, refillable  
 (12) 2" MERV 11 and (12) 2" charcoal/poly pads (replaceable) w/(12) 2" poly after-filters

**OTHER OPTIONS:**  Pressure gauge kit indicates filter changes.  
 Side shields

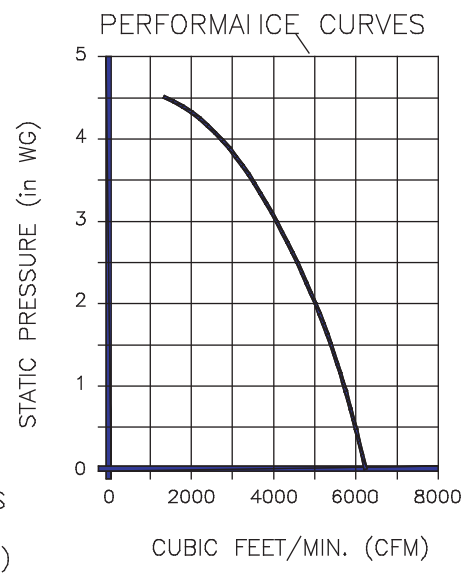
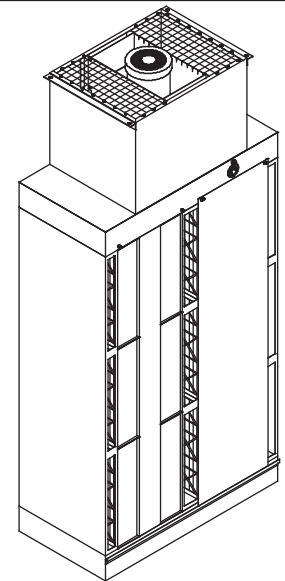

THE DEVICE DEPICTED AND DESCRIBED HEREON EMBODIES PROPRIETARY INFORMATION OWNED BY AIRFLOW SYSTEMS, INC. ALL DESIGN, MANUFACTURING, REPRODUCTION, SALES, AND PATENT RIGHTS REGARDING THIS DEVICE OR DRAWING ARE RESERVED EXCEPT WHERE EXPLICIT RIGHT IS GRANTED IN WRITING.

**Diversified Air Systems, Inc.**  
**Phone: 800-264-8958**

DRAWN BY CB	TITLE PANEL FILTER POWER BOOTH
DATE 5-7-08	
SCALE NTS	DRAWING NO.: PFPBSPEC (79-4462/A)

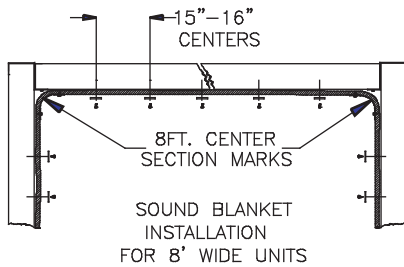

(PANEL FILTER BOOTH SHOWN LESS FILTER COVER PLATES)

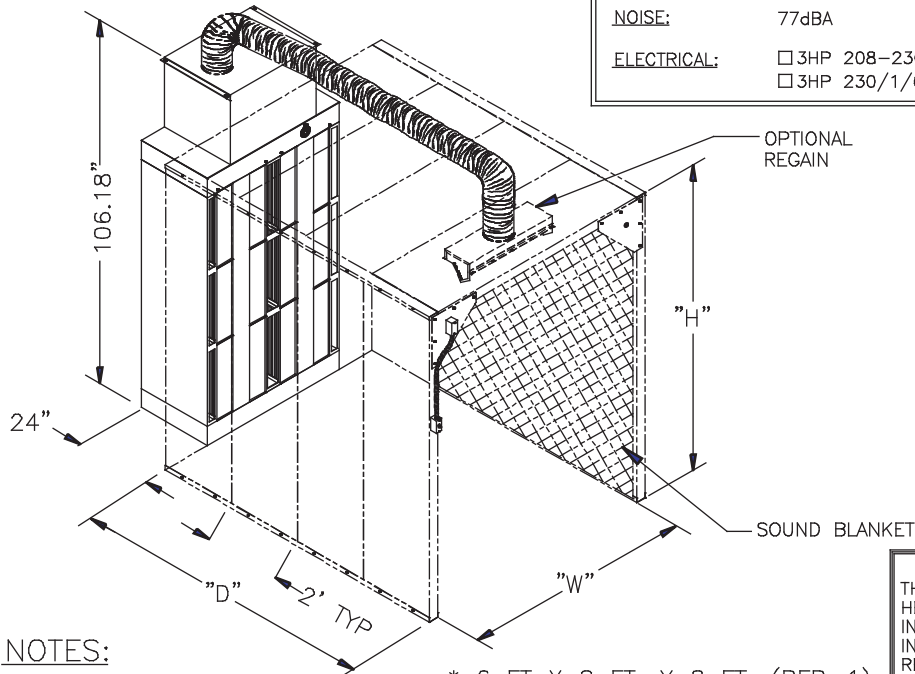

**NOTES:**

\* 6 FT X 8 FT. X 8 FT. (PFB-1) BOOTH SHOWN

**SPECIFICATIONS:**

**CONSTRUCTION:** PANEL FILTER BOOTH: 16 Ga. welded zinc coated steel cabinet, finished with Powder-Coat finish. Includes a removable access panel to motor and direct drive, ball bearing, B.I. blower, and an acoustic lined inlet plenum and blower compartment. Motor wired to junction box outside unit. Motor starters/disconnects NOT included.

ROOF AND SIDE PANELS (Each): 16 Ga. galvanized steel, 8 feet high, 2 feet wide, and 3 inches deep, with a roof loading of 200 pounds.

**WEIGHT:** Panel Filter Booth - 520 lbs.; Panels - 6' = 40 lbs.; 8' = 53.3 lbs.; 12' = 80 lbs.; 16' = 106.56 lbs.

**AIRFLOW:** 5000 CFM per module  
4500 CFM W/HEPA or AD modules

**SOUND CONTROL:** Double insulated sound panels with 3" dead air space behind for maximum acoustical control in work area.

**LIGHT:** Minimum of (2) 80 watt, dust-tight, fluorescent lights.

**NOISE:** 77dBA

**ELECTRICAL:**  3HP 208-230/460/3/60, 7.8-7.2/4 amps, std.  
 3HP 230/1/60, 11.7 amps, opt.

**PREFILTERS:**  (2) 24 x 72 x 2 Poly (OPTIONAL)

**MAIN FILTERS:**  (12) 24 x 24 x 6 MERV 11, 42<sup>2</sup> ft. each, std.  
 (36) 24 x 24 x 2 MERV 11, opt.

**HEPA OPTION:**  (12) 2" MERV 11 and (12) 4" 99.97% Mini-pleat HEPAs

**DOP OPTION:**  (12) 2" MERV 11 and (12) 4" 95% Mini-pleat DOPs

**AD OPTION:**  (12) 2" MERV 11 and (12) 3" 30 lb. AD modules, refillable

**OTHER OPTIONS:**  Pressure gauge kit indicates filter changes.  
 Silencer  
 Regain

**FIRE SUPPRESSION:** Equipment provided by others.

UNIT	W	D	H	QTY OF TOP PANELS	QTY OF PANEL FILTER BOOTHS
PFB-1	6'	8'	8'	(4) 6' LONG	1
PFB-2	8'	8'	8'	(4) 8' LONG	2
PFB-3	12'	8'	8'	(8) 6' LONG	3
PFB-4	16'	8'	8'	(8) 8' LONG	4

THE DEVICE DEPICTED AND DESCRIBED HEREON EMBODIES PROPRIETARY INFORMATION OWNED BY AIRFLOW SYSTEMS, INC. ALL DESIGN, MANUFACTURING, REPRODUCTION, SALES, AND PATENT RIGHTS REGARDING THIS DEVICE OR DRAWING ARE RESERVED EXCEPT WHERE EXPLICIT RIGHT IS GRANTED IN WRITING.

**Diversified Air Systems, Inc.**  
**Phone: 800-264-8958**

DRAWN BY CB	TITLE PANEL FILTER DUST CONTROL BOOTH
DATE 5-4-07	DRAWING NO.: PFDCBSPC (79-4356/A)
SCALE NTS	