

PAC-91 Portable Air Cleaner/Collector



Shown With Optional
Dual Arm Configuration

Dimensions

Width:	26.00"
Height:	66.00"
Depth:	40.00"

Options

- **Dual Arms:**
Provides up to 600 CFM per arm.
- **HEPA Final Filters:**
99.97% DOP efficiency.
- **Adsorption Filter:**
Refillable filter to control gases and odors; available with a variety of sorbents.
- **65-Watt Halogen Light Kit:**
Improves worker visibility.
- **Oversized Wheels:**
Provides additional stability, ideal for rolling over rough surfaces.
- **Hazard Location Electrical:**
Groups D, E, F, and G.
- **14-ft. E-Z Arm® High Flow Extractor**
Provides longer reach.

Features & Benefits

- **Complete, self-contained unit:**
Versatile, easy to use; no installation required.
- **10-ft. E-Z Arm® High Flow Extractor:**
Self supporting external arm provides for maximum performance, reduces operator fatigue.
- **Efficient source capture:**
95%+ filtration efficiency produces cleaner air; system simplifies OSHA and insurance compliance.
- **Direct-drive blower:**
Higher static pressure, longer filter life and greater reliability; non-sparking; no belts or pulleys to replace.
- **Non-electrostatic operation:**
High reliability, low maintenance.
- **Narrow width design:**
Permits access and maneuverability in tight spaces.
- **Plug-in operation with any 115V outlet:**
Can be used anywhere, no special wiring required.

Specifications

Construction:

16 ga. steel cabinet, powder coated

Blower Pkgs (HP):

1.5, 2.0, 3.0

Noise Level (dBA):

78 standard

Electrical:

1.5 HP - 115/1/60, 208/230/460/575/3/65, 5.7/5.4/2.7 amps.

2.0 HP - 208/230/460/575/3/60, 5.7/5.4/2.7 amps.

1.5 HP - 220/1/50, 6.6 amps.

Nominal CFM (in.):

1000/1200, 1.5/2.0, 60 Hz

1000, 50 Hz

Weight (lbs.):

389

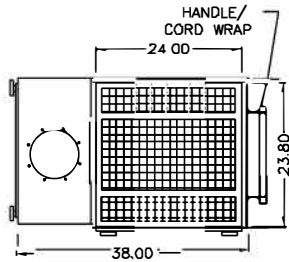

TOP VIEW
(WITH OPT. HEPA/AD OUTLET SHOWN)

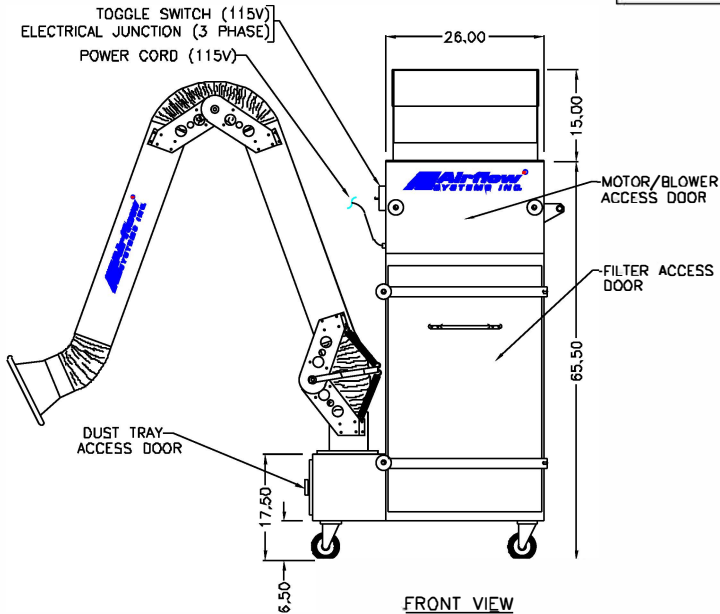

FRONT VIEW

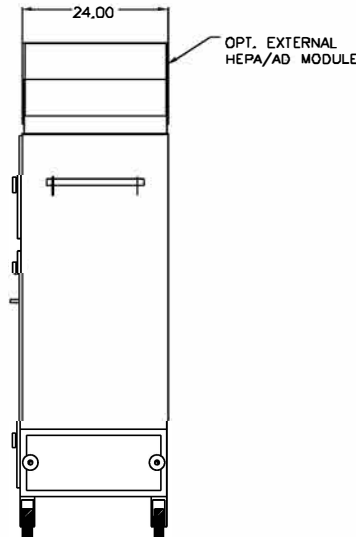

SIDE VIEW

SPECIFICATIONS:

CONSTRUCTION:

16 gauge all welded steel cabinet, finished with a Powder-Cool finish. Includes Ultra-Seal® filter mounting system, side access door to filters and direct drive motor/blower, 10' E-Z ARM® High Flow Extractor arm, 5" casters, power cord, and on-off switch (115V units). Three phase units wired to electrical junction box. (Circuit and motor overload protection by others.)

WEIGHT:

369 lbs.

AIRFLOW:

1000 CFM, 1.5 HP, std.
1100 CFM, 2 / 3 HP, opt.
900 CFM, HEPA, 2 / 3 HP, opt.

ELECTRICAL:

- 1.5 HP, 115/208-230/1/60, 17.0/8.5 amps, std.
- 1.5 HP 208-230/460/3/60/50, 4.9-4.6/2.3 amps, opt.
- 2 HP 208-230/460/575/3/60, 5.7-5.4/2.7 amps, opt.
- HP-3 HP 208-230/460/575/3/60, 8.0/4.0 amps, opt.

NOISE:

78 dBA , 68 dBA w/ silencer.

FILTER SEAL:

Ultra-Seal® filter sealing locking mechanism for all main filters, optional HEPA filters and/or adsorber modules (when used). Slide in tracks shall be used for prefilters only

FIRE SUPPRESSION: Equipment provided by others.

PREFILTERS:

- (1) 2" aluminum mesh, std.
- (1) Chevron® mist eliminator, opt.

MAIN FILTERS:

- (1) 88 ft² high pressure bag, 95%, std.
- (1) 65% short bag, opt.
- (1) Easy clean, opt.
- (1) Short bag followed by 95% D.O.P. (int), opt.
- (1) Shaker bag, opt.

HEPA OPTION:

- (1) External HEPA, 99.97%, opt.
- (1) Short bag followed by 99.97% HEPA (int), opt.

AD OPTION:

- Std. prefilter followed by 36 ft², 95% short bag filter, followed by (2) 25 lb. refillable v-bank carbon modules, followed by a 2" pleat afterfilter

OTHER OPTIONS:

- Pressure gauge kit indicates filter changes
- 14' E-Z ARM® High Flow Extractor
- Dual 10' E-Z ARM® High Flow Extractors

* AFS FILTER EFFICIENCIES BASED ON ASHRAE 52-76 TEST METHOD
ALL FLOWS STANDARD AIR AND FILTERS UNLESS OTHERWISE INDICATED.

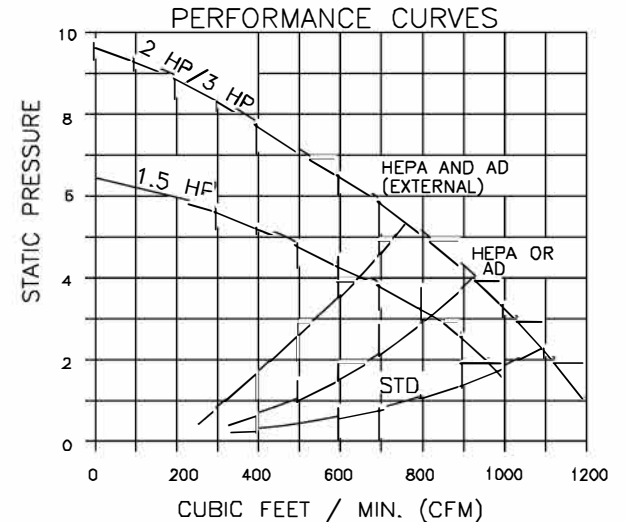

NOTES:

Items designated as are included in this proposal.

THE DEVICE DEPICTED AND DESCRIBED HEREON EMBODIES PROPRIETARY INFORMATION OWNED BY AIRFLOW SYSTEMS, INC. ALL DESIGN, MANUFACTURING, REPRODUCTION, SALES, AND PATENT RIGHTS REGARDING THIS DEVICE OR DRAWING ARE RESERVED EXCEPT WHERE EXPLICIT RIGHT IS GRANTED IN WRITING.

Diversified Air Systems
Phone: 1-800-264-8958

DRAWN BY
CB
DATE 5-9-00
SCALE

TITLE
MODEL PAC-91 (BAG)
PAGE 1 OF 2
DRAWING NO.: PAC91SPC (92-2659)

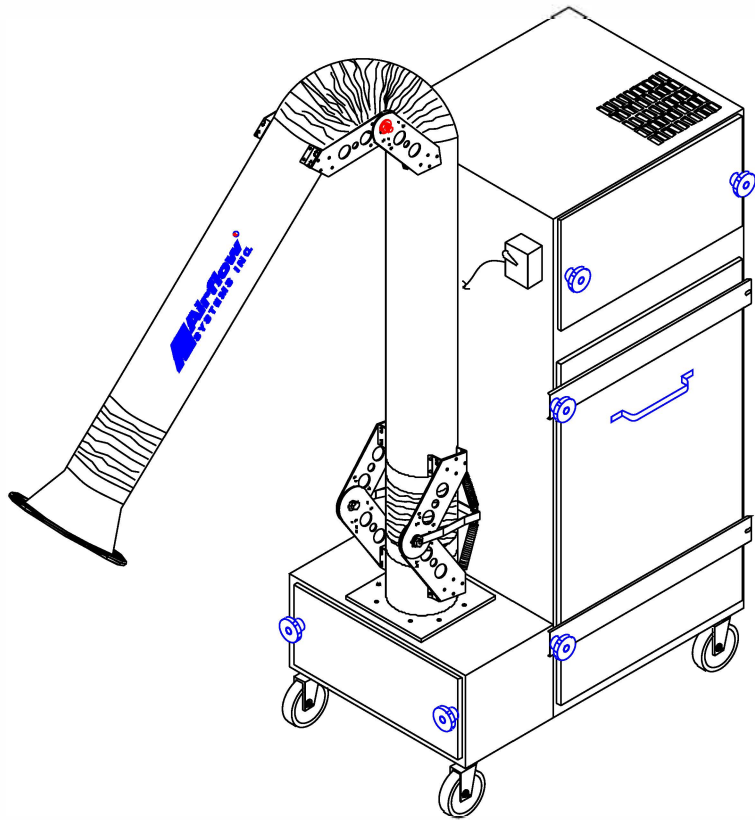

STD WITH 7E10
E-Z ARM®

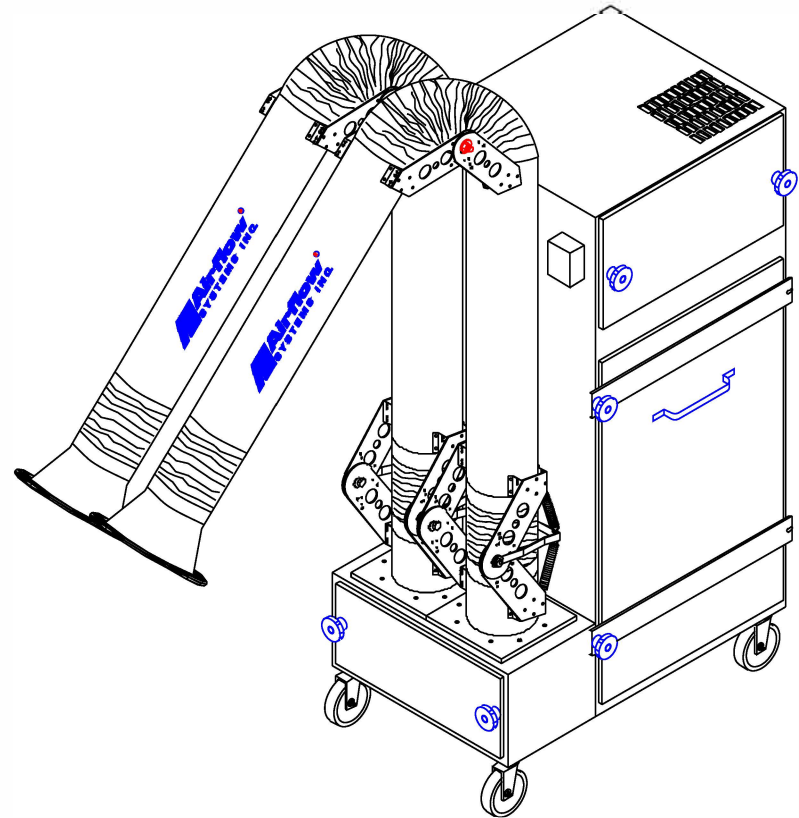

OPTIONAL DUAL
ARM UNIT

NOTES:

THE DEVICE DEPICTED AND DESCRIBED
HEREON EMBODIES PROPRIETARY
INFORMATION OWNED BY AIRFLOW SYSTEMS,
INC. ALL DESIGN, MANUFACTURING,
REPRODUCTION, SALES, AND PATENT RIGHTS
REGARDING THIS DEVICE OR DRAWING ARE
RESERVED EXCEPT WHERE EXPLICIT RIGHT
IS GRANTED IN WRITING.

Diversified Air Systems
Phone: 1-800-264-8958

DRAWN BY
CB
DATE 5-9-00
SCALE

TITLE
MODEL PAC-91 (BAG)
PAGE 2 OF 2
DRAWING NO. PAC91SPC (92-2659/1)