

TC-4 Free-Hanging Dust Collector

Features & Benefits

- **Class II direct-drive blower:**
Higher static pressure, longer filter life and greater reliability; non-sparking; no belts or pulleys to replace.
- **Non-electrostatic operation:**
High reliability, low maintenance.
- **Four-way adjustable airfoil grille:**
For precision direction of air back into facility.
- **Maximum air flow design for light to medium applications:**
Improves operating efficiency.
- **Prewired to junction box:**
For fast, easy installation.
- **Cleanable Filters:**
Reduces filter replacement costs.
- **Vibra-Pulse® Filter Cleaning System:**
Cleans filters 75% more effectively than reverse pulse systems.
- **Auto-Clean off-line filter cleaning:**
Automatically cleans filters when unit is shut off.
- **Dual Hopper Design:**
Extends maintenance cycles.

- **Regulator**

Specifications

Construction:

16 and 18 ga. steel cabinet, powder coated

Blower Pkg (HP):

3.0, 60 Hz
2.0, 50 Hz

Noise Level (dBA):

82

Electrical:

3.0 HP - 208-230/460/575/3/60, 8.6/4.3/3 amps, std.
2.0 HP - 190/380/3/50, 7.2/3.6

Nominal CFM (in.):

2650, 60 Hz
2150, 50 Hz

Weight (lbs.):

450

Dimensions

Length:	77.00"
Height:	32.00"
Depth:	31.00"

Options

- **Pressure Gauge Kit:**
Indicates when filters require cleaning.
- **Silencer:**
Reduces noise by 4 dBA.
- **Mounting Brackets:**
Speeds installation, reduces maintenance expense.

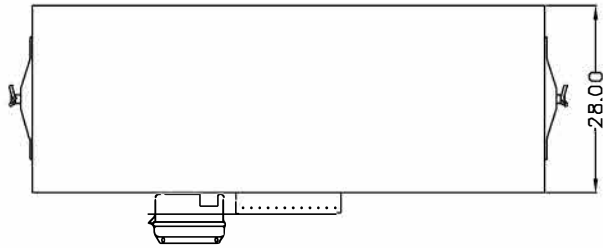

TOP VIEW

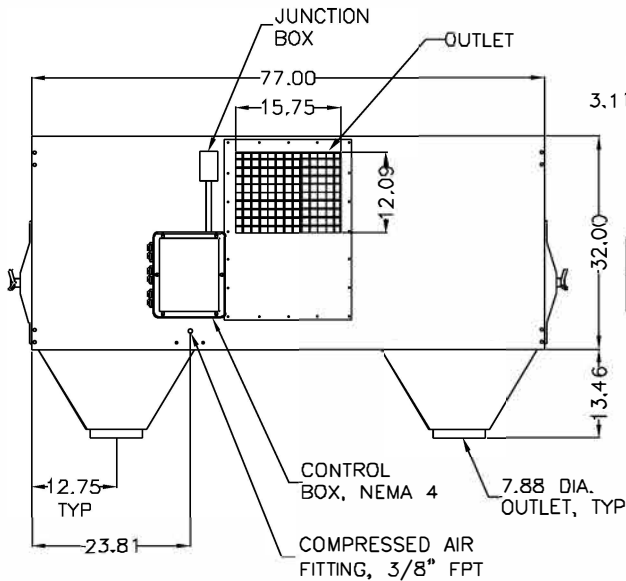

SIDE VIEW

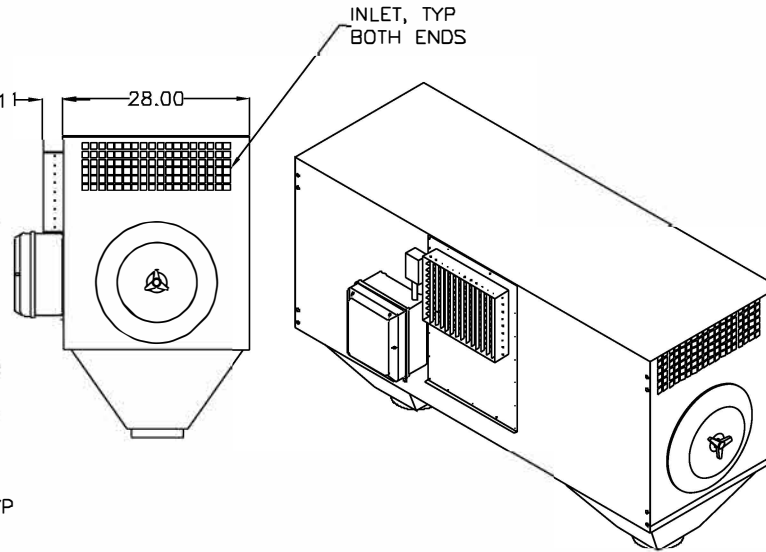

END VIEW

SPECIFICATIONS:

CONSTRUCTION: 16 and 14 Gauge steel cabinet finished with a 2-part chemical and oil resistant paint. Includes side access panel to motor, removable endcaps for easy access to filters, (2) hoppers with a 7.88 diameter outlet, automatic filter cleaning, and a direct driven, ball bearing, BI blower w/4-way adjustable airfoil blade exhaust grille. Motor wired to junction box outside unit. Motor starters/disconnects not included.

WEIGHT: 450 lbs. SHIP WT: 685 lbs.

AIRFLOW: 2650 CFM
2500 CFM - 50HZ

NOISE: 82 dBA / 78 with silencer

ELECTRICAL: 3 HP 208-230/460/575/3/60, 8.6/4.3/3 amps, std.
 3 HP 220/380/440/3/50, 8.4/4.7/4.2 amps, std.

MAIN FILTERS: (4) 150 ft² CLEAN 2⁰ cartridges, std.
 (4) 75 ft² Fiber Dust⁰ cartridges, opt.
 (4) Spunband cartridges, opt.

OTHER OPTIONS: Pressure gauge kit indicates filter changes
 Mounting brackets
 Silencer

* AFS FILTER EFFICIENCIES BASED ON ASHRAE 52-76 TEST METHOD

PERFORMANCE CURVES

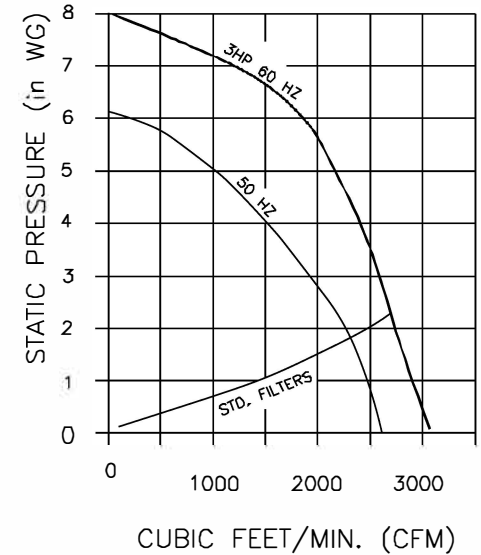

NOTES:

Items designated as are included in this proposal

THE DEVICE DEPICTED AND DESCRIBED HEREON EMBODIES PROPRIETARY INFORMATION OWNED BY AIRFLOW SYSTEMS, INC. ALL DESIGN, MANUFACTURING, REPRODUCTION, SALES, AND PATENT RIGHTS REGARDING THIS DEVICE OR DRAWING ARE RESERVED EXCEPT WHERE EXPLICIT RIGHT IS GRANTED IN WRITING.

Diversified Air Systems, Inc
Phone: 800-264-8958

DRAWN BY
CB
DATE
10-6-00
SCALE

TITLE
MODEL TC-4

DRAWING NO.: TC-4SPEC (29-2876/B)